

# Many Happy Returns

No. 37

\$2.50

An International Publication of the United States Boomerang Association

Winter 1989

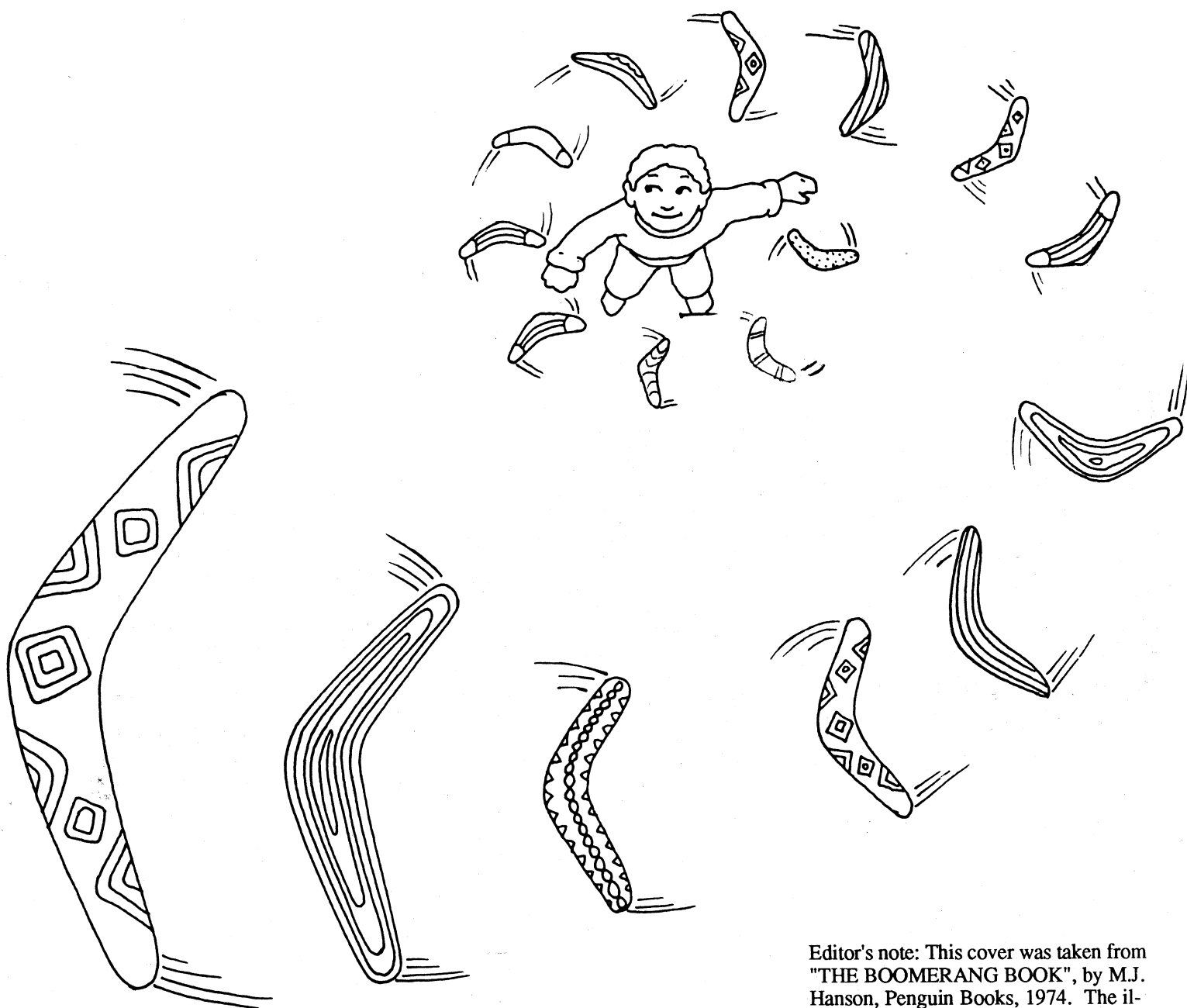

Editor's note: This cover was taken from "THE BOOMERANG BOOK", by M.J. Hanson, Penguin Books, 1974. The illustrations were drawn by Robin Lawrie.



## WHAT'S HAPPENING IN THIS ISSUE?

USBA Videotape Library	2
1989 Tournament Season	2
USBA Rules Committee	3
Third International Team Cup	3
More Fairy Tales Come True	3
Boomerangs in Literature	4
Boomerangs on Television	5
Boomerangs in Music	5
News from Germany	5
World's Oldest Boomerang	5
New Products	6
News from Sweden	6
News from France	7
News from Brazil	7
Boomerangs & Computers	8
Boomerang Designer	8
Computer Designed Booms	10
Perry Tours the U.S.A.	15
Team Gel's Ct. Boomtest	16
Summer's Final Fling	16
World's Largest Boomerang	16
1988 World Cup	17
1988 Qantas Picnic Demo	18

### 1988 USBA RATINGS

A preliminary copy of the 1988 USBA rating system results is available by sending a SASE to the USBA address listed below:

**USBA**  
**P.O.Box 182**  
**Delaware, Ohio 43015**

The final results will be published in the Spring issue of MHR.

## USBA VIDEOTAPE LIBRARY

The USBA has an excellent video archival system for the benefit of USBA members. The archives are loaded with assorted clips on domestic and overseas boomerang events. Domestic USBA members can purchase any of the following tapes for a price of \$30 each, P&H included:

- 1: Overseas Boomerang Movement
- 2: USA Boomerang Movement
- 3: Boomerang Collecting; Part I
- 4: Boomerang Collecting; Part II
- 5: 1987 International Team Cup Highlights
- 6: 1987 International Team Cup Banquet
- 7: 1986 USBA Nationals: Georgia
- 8: 8<sup>th</sup> Annual Peabody Museum Boomerang Lecture/Demo
- 9: 1986 Palenville Tournament
- 10: 1987 Team Gel Boomtest; Ct.
- 11: 1986 Potomac Tournament

The most exciting tapes include tapes 1&2 which are composed of news clips and tid bits from all kinds of sources. Spread over a 10 to 15 year time period, they represent an excellent chronological history of the development of the boomerang movement in the 1970s and 1980s.

Tape 6 captures the fever generated by the first International Team Cup as everyone lets loose following more than a week of intense competition. The highlights of the evening's festivities include Michael Gel Girvin demonstrating what it's like to be Gel Rad.

Tape 9 begins like any other boomerang tournament tape until the MTA event. Then all hell breaks loose as ideal conditions lead to lots of lost boomerangs and the setting of an MTA world record by Larry Ruhf. The hoopla that follows captures the essence of a kind of excitement that few can ever hope to achieve in a lifetime.

Orders can be placed through Gary Lemothe at the address below. Include \$1 and a SASE and ask for a complete listing of USBA Archives. Other material can be copied for a nominal charge.

**Garry Lemothe**  
**18 St. James Ave.**  
**Easthampton, Ma. 01027**

## 1989 TOURNAMENT SEASON - U.S.A.

It's time to make plans for the 1989 competition season. The listing below is the tentative schedule for the season. Note that we do not have a location or date for the USBA Nationals. Hopefully a site will be selected by the Spring issue. The Third International Team Cup is tentatively scheduled to be held in the Gaithersburg/Washington D.C. area. The USBA has a **TOURNAMENT HOTLINE** that can be called 24 hours a day at the following number: (619)-298-4283

**April 29 - Swainsboro, Ga.**  
 John Derden; 9 Cole Grove Dr.  
 Swainsboro, Ga. 30401  
 (912)-237-7207

**May XX - Hampton Roads, Va.**  
 Dennis Joyce; 44 Lucinda Ct.  
 Hampton, Va. 23666  
 (804)-838-4790

**June XX - Gaithersburg, Md**  
**International Team Cup**  
 Larry Ruhf; 31 Jackson Road  
 Belchertown, Ma. 01007  
 (413)-323-4340

**June 24 - Portland, Or.**  
 Marjorie Gerrish; 4885 S.W. 78<sup>th</sup> Ave.  
 Portland, Or. 97225  
 (503)-292-4316

**July 15 - Meridan, N.H.**  
 John Flynn; R.R. #2 Box 209-8  
 White River Junction, Vt. 05001  
 (802)-296-2158

**August 5 - Delaware, Ohio**  
 Chet Snouffer; 51 Troy Rd.  
 Delaware, Ohio 43015  
 (614)-363-8332

**August 6 - Cleveland, Ohio**  
 Dave Boehm; Box 17385  
 Euclid, Ohio 44117  
 (216)-442-6024

**September 9 - St. Louis, Mo.**  
 Tom Fitzgerald; 1159 Holly River  
 Florissant, Mo. 63031  
 (314)-839-1604

**September 17 - Portland, Or.**  
 Doug DuFresne; 4235 S.W. Crestwood  
 Portland, Or. 97225  
 (503)-292-4316

---

---

## USBA RULES COMMITTEE

---

---

by Chet Snouffer

The Rules Committee is spending the Holiday Season fine tuning the rules for 1989. The committee includes John Flynn, Peter Ruhf, Betsy Miale, John Derden, Doug DuFresne, and Chairman Chet Snouffer. The goals this year are to fine tune the the loop holes and format for the existing events, publish a new, inclusive rule book for the 1989 season, and work with other international boomerang organizations to clarify a set of international standards in the key events.

Items that the committee are addressing include "clean" catches for Consecutive Catch and Doubling. Also under consideration are "count-up" formats for the above two events. This would allow each competitor to throw a certain number of times regardless of any drops, and the total score (for example: 8 out of 12) would be their score. In the case of ties for top score, the surviving throwers would go to the familiar single elimination format now used in Consecutive Catch and Doubling, where, if you drop, you are "out".

The complete rule book should be available in early spring in time for the first competition. Details will be in the Spring issue of MHR or Leading Edge newsletters; or call Chet at (614)-363-8332.

---

---

## THIRD INTERNATIONAL TEAM CUP - 1989

---

---

The third International Team Cup is tentatively scheduled to be held in the Gaithersburg/Washington, D.C. area sometime in June over a nine day period, spanning two weekends. Three team test matches will be separated by two individual events. The first will be an open tournament for throwers of any nationality for the purpose of determining an individual world champion. An additional match will be held to bring the best throwers in the world together for a special throw off. The prime event to be contested will be long distance since this event has not been held on American shores for quite some time. Other events such as MTA, Fast Catch & Super Catch will also be in contention. If you are not on a team and have interest in participating in this special festival, contact ITC coordinator: Larry Ruhf at the address on page 2.

---

---

## MORE FAIRY TALES COME TRUE

---

---

Arthur Scholtz of Yaphank, N.Y. had his a miniature boomerang with fluorescent orange tips stolen by none other than a porpoise. He did not elaborate on the details.

Don Durrett of Parlin, N.J. writes to tell MHR about the two long distance Behrens' "Challenger III" boomerangs he purchased from Ben Ruhe. He recently measured a throw of 145 yards with a complete return. The boomerang had five ounces of lead weight on it and needed a horizontal launch. Don said he throws near a road and stops traffic with the awesome sight of his sticks travelling such incredible distances.

Uli Konzelmann of Leutenbach, West Germany is known for his rocket arm & skill as a competitor. In competition at the Swiss Nationals & International Team Cup in Geneva this past summer, he did Super Catch with 6 catches. In practice under ideal conditions, he can do 10 catches. Who can top this?

Gerhard Bertling of West Berlin successfully threw a boomerang from west to east and back to west over the infamous Berlin Wall on the evening of August 27, 1988. The feat was accomplished several times.

From the BBS Autumn 1988 Newsletter comes an accounting of a throw around the South Pole by a Lefty named Jay Perrett. The following commentary was supplied by Bob Reid, a lecturer in the Physics department of Leeds University: *On February 12, 1988, Jay Perrett stood 15 metres North (?) of the newly surveyed polar axis while straddling the Greenwich Meridian. Thrown with his left hand, the boomerang circumnavigated the pole in an anticlockwise direction, setting an MTA record of 1 day and 9 seconds and the fastest time around the world, all at the same time. Catching was difficult at an altitude of 9,000 feet and a temperature of minus 90 F. Boomerang Fever has spread throughout the Amundsen-Scott Base near the South Pole. Packing cases and printed circuit boards are under heavy guard. The polar boomerang now resides in a display at the University of Leeds. Additional scientific staff, skilled in the art of boomerang throwing returned to the South Pole in November, 1988.*

---

---

## SUPER CATCH HONOR ROLL

---

---

Ted Bailey  
Gary Broadbent  
Rob Croll  
Eric Darnell  
Doug DuFresne  
John Flynn  
Torsten Fredrich  
Mike Forrester  
Michael Girvin  
Rob Greer  
Thomas Hartmann  
Dennis Joyce  
John Koehler  
Uli Konzelmann  
Ray Laurent  
Gerrit Lemkau  
Barnaby Ruhe  
Chet Snouffer  
Olivier Vouktchevitch

### BOOMERANGS

by Ted Bailey

I buy and sell Collectible Boomerangs as well as Australian Aboriginal artifacts and related antiquities. I also sell hand made high performance competition boomerangs. Write today to the address below & get on my mailing list:

Ted Bailey  
2967 Gracewood Rd.  
Toledo, Ohio 43613

# DAN RUSSELL

P.O. Box 84895  
San Diego, Ca. 92138

Write for a free catalog of  
Dan Russell's quality  
boomerang products today!

## BOOMERANGS IN LITERATURE

Jim Mayfield received nice publicity in the Summer 1988 issue of **GUNNISON COUNTRY** magazine. The article titled "Boomerangs . . . four dimensional art" covers Jim's design techniques as well as a generic overview of the contemporary boomerang movement.

Wilhelm Bretfeld supplied us with a copy of a beautiful book written by Clara B. Wilpert in German titled "**Der Flug des Bumerang - 40,000 Jahre Australier**". The book (pictured below) was written in support of an exhibition (by the same name) that took place in Hamburg, West Germany from June through September 1988 and continues in Koln from October 1988 through February 1989. Wilhelm is a co-author, writing a section titled "Geheimnisvoller Bumerang". The exhibition featured a fine selection of both Australian Aboriginal boomerangs as well as contemporary boomerangs with props to demonstrate boomerang kinematics.

"Der Flug des Bumerang - 40,000 Jahre Australier" can be purchased directly from Wilhelm Bretfeld. The price is \$10 (USA) + shipping from Germany. Allow approximately \$5 for airmail postage from Germany to the USA. You may contact Wilhelm at the following address:

Wilhelm Bretfeld  
Postfach 3230  
2000 Norderstedt  
West Germany

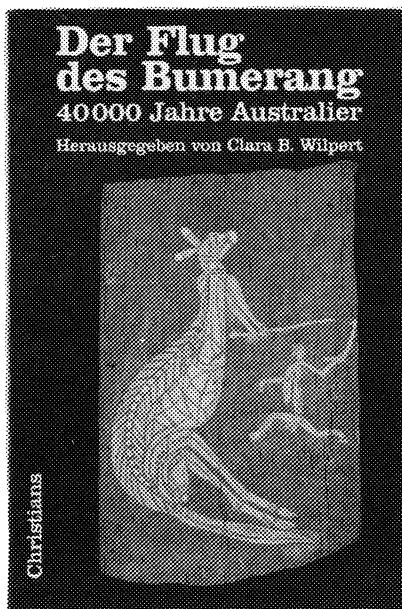

Jim Gasser purchased a book for his two year old son titled "A TROLLEY VISIT TO MAKE-BELIEVE" which summarizes the characters in Make-believe land on the **Mister Rogers'** television show. There is a character called Lady Elaine Fairchilde who collects things in her Museum-Go-Round. She has a Boomerang Toomerang Soomerang that she waves when she wants something to happen. You can't miss this book in the book store. It is shaped like a trolley car and comes with its own wheels. Priced to sell at \$5.95.

Gary Broadbent has his eyes open for boomerang theme greeting cards. He sent us the three cards depicted on the right side of this page. The top card, designed by **Kevin Pope** is available where **ACME** greeting cards are sold. The middle card is a **Hallmark** Birthday Card designed by **J. Wagner**. The bottom card, created by **Polly Brewer** is also a birthday card available through **Argus Communications**.

On page 812 of the December, 1948 issue of **National Geographic** is an article on the evolution of the modern arabic numerals. An evolutionary flow chart of various letters which originated in ancient Egyptian hieroglyphics shows that the letter "P" evolved from the Egyptian hieroglyphic character for the hunting stick. The pictograph looks remarkably like an Australian Aboriginal non-returning throw stick or hunting stick.

Garry Lamothe sent in an article out of the May 2, 1988 issue of **U.S. News & World Report** which featured a peek at the new B-2 Stealth bomber. The article begins: "*It looks dismayingly like a huge boomerang . . .*". Gunther Veit of West Germany wrote to say the similarity to a boomerang was even mentioned on a German TV News show.

Gunther Veit writes of a German book titled "**Der Amerikanische BUMERANG**" by Christopher Simpson. The book deals with Nazi war criminals that accepted \$\$ from the United States.

Will Gix of Edmonds, Wa. recieved excellent coverage, including two photos in the Fall/Winter 1988 issue of **HFC Headliner**, an employee newsletter of the Household Finance Company.

Dave Hetrick of Topeka Ks. found an ad for a Toyota Land Cruiser in the December 12, 1988 issue of **Sports Illustrated**. The ad pictures a rugged Aussie leaning against a fence holding onto a boomerang. "*It takes a special calibre to conquer the grueling Australian Outback.*"

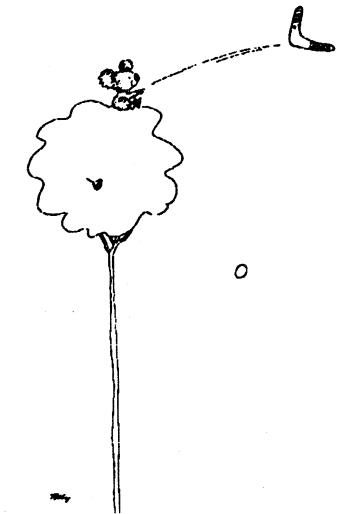
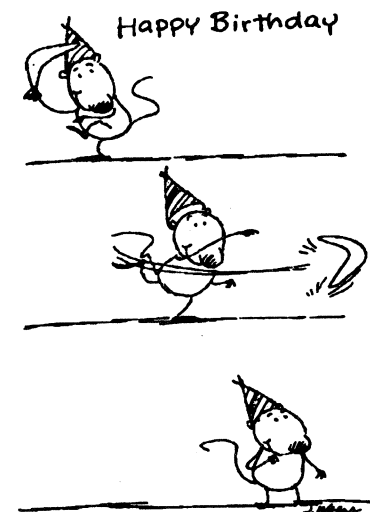

## BOOMERANGS on TELEVISION

At press time, the GTE sponsored DISCOVER show (PBS) was supposed to air a one hour special on Australia (including a segment on the 1988 World Cup in Australia) on December 19, 1988. Hopefully some one will catch this piece for the video archives. Kristian Almquist found a full page ad for this show in the December 1988 issue of *Health*.

Another TV show which will cover the sport of boomeranging is the ESPN Saturday morning show: *Sunkist Kids*. Segment #19 out of 25 will feature Mark Tilford of Delaware, Ohio. Don't miss this one, it won't air until after you have this issue of MHR.

Garry Lamothe writes in the following account by Jeff Lacourt (Webtown Team Member) of Easthampton, Ma.: *Jeff's grandmother was watching the T.V. game show Wheel of Fortune and saw Pat Sajak throw a boomerang out over the audience and catch it on it's return.* The episode took place in early November, 1988.

Tom Fitzgerald captured several TV news stories covering the first St. Louis Boomerang Tournament last September. Segments were sent to the USBA Video Archives. Another interesting publicity gimmick is the radio. Tom had a local radio station give away free boomerangs as a promotion of his tournament and workshop. Interviews by Chet Snouffer and Roger Perry helped to make the workshop a sell out. Several local newspapers also got in the promoting act with extensive coverage. Tom, a sales manager, is one of the best promoters in the business.

Gunther Veit of West Germany writes about an interesting advertisement on German television. Commercials are not inserted within movies on German television. Instead, they are put between films. Each commercial is separated by short cartoons. One goes like this, as related by Gunther: *A monkey throws a boomerang which flies out of sight - commercial - it comes back very fast, the monkey steps aside as the boomerang flies away again - commercial - the boomerang comes back again and the thrower has to bend down to avoid injury - commercial - the boomerang returns again. The monkey keeps cool, raises one leg and catches the boomerang with his foot. Then he asks the audience: "Is the boomerang allowed to do this?"*

## BOOMERANGS in MUSIC

Gunther Veit of West Germany has a collection of music with a boomerang theme or with boomerang in the title. He notes that there are three tracks in Jazz titled "Boomerang". These include: **Blue Mitchell Quintet**, **Clark Terry Quintet & Paul Motian Band**. Several years ago, Gunther found a record shop in Marseille, France that carried an LP by an Italian piano trio called "I Cauio". The LP (Vedette Records VPA 8335) was titled "Boomerang". The cover shows a man throwing a boomerang that flies high in the sky hitting something resembling a cloud on which the piano trio is playing. Gunther once received a maxi single record as a birthday gift from a friend titled "Mein Bumerang". It has a red sticker showing a white boomerang and the following sentence: *"Don't throw away! This single always comes back"*. A rough translation of the refrain into English sounds like: *"My boomerang flies around the corner and brings back some pieces out of the clouds"*.

## NEWS FROM GERMANY

Gunther Veit writes to tell us that the **Deutscher Bumerang Club** has a new president: Eckhard Mawick. Eckhard's new duties include editing the DBC Bulletin as well as insuring that the DBC sails smoothly into 1989 activities. Gunther, who held the position of President for many years, as the DBC grew to the largest boomerang organization in the world, will remain as a member of the board of the DBC.

## WORLD'S OLDEST BOOMERANG

Dr. Pawel Valde-Nowak of the Polish Academy of Sciences discovered the world's oldest boomerang in a Polish cave two years ago. He has agreed to replicate the 20,000 year old boomerang constructed out of a mammoth tusk section. The cost of a single replication is \$250 as special materials from Germany must be used to avoid damaging the pre-historic implement. It is possible that more than one copy can be made with a decrease in the unit price. If you are interested in obtaining a replica, contact Ted Bailey immediately for details at: (419)-471-9989



### BOOMERANG MAN

1806 North 3rd. RM  
MONROE, LOUISIANA 71201

(318) 325-8157

Hours: 10 A.M.-12 Noon & 2 P.M.-5 P.M. (Central Time)

### 13th ANNUAL FREE CATALOG!

Always something new and exciting!

MOOMBA!!!!

"Giving fast, personal service always."

Rich, The B-Man

"Your satisfaction guaranteed."

Copyright  
1987

---

---

## NEW PRODUCTS

---

---

Anderson International Trading writes to remind MHR that they carry a full line of Finland Birch Plywood and Birch Aircraft Plywood. Of special note to boomerang craftsmen are premium grade 5 mm aircraft birch with 10 ply and 6 mm aircraft birch with 12 ply from a top lumber mill in Finland. Boomerang manufacturers would do well to call or write and ask for a catalog at the following address:

**Anderson Int'l Trading**  
825 N. Cypress St.  
Orange, Ca. 92667  
(714)-771-6270

Gary Broadbent of Cleveland, Ohio has decided to thin down one of the largest boomerang collections in the world. More than 2,000 boomerangs to choose from. Specimens include Australian Aboriginal Natural Elbows (returners and kylies), Al Gerhards laminated all styles, Competition boomerangs of all kinds, and anything else you can imagine! Interested parties can contact Gary at (216) 327-7796 or write to the following address:

**Gary Broadbent**  
5327 Wallace Blvd.  
North Ridgeville, OH 44039

Christian Franke of West Germany is offering a fine line of boomerang products constructed out of quality plywood and a material called Makrolon, which is virtually indestructible. Prices are very reasonable at about DM 25 for the plywood models and DM 35 for the Makrolon models. Additional postage of approximately DM 5 is required for shipping from the USA. The conversion rate is approximately \$1.50 for each DM. Christian mailed MHR a sample Makrolon Hook which is nicely finished and has superior performance. Any readers who wish to obtain price information can write

to Christian at the address below:

**Christian Franke**  
Riedstrasse 9  
D-6102 Pfungstadt 4  
West Germany

The Boomerang Man always has a supply of new products on hand at any given time. Here is a great source to get collectables and performance 'rangs at a good price without having to write to manufacturers all over the world and having to pay high prices for shipping small quantities over great distances. The Boomerang Man carries specialty boomerangs such as the Rod Jones Christmas collectible series (each year has a different theme), and the high performance Colorado Boomerangs made by Jim Mayfield. The Greg Nolan Art boomerangs, described in MHR issue #36 is another new product line. Check with the B'Man for fantasy art & animal art boomerangs by Alan Craig, reviewed in MHR #35. Perhaps the most exciting new B'Man products are the high performance boomerangs by Roger Perry with their glossy bright finishes. If you haven't seen the Boomerang Man special products sheet lately, you should drop him a line at the following address:

**Boomerang Man**  
1806 No. 3<sup>rd</sup> Street  
Monroe, La. 71201-4222

Ben Ruhe has discovered an incredible MTA device called the Walkalong Wing. The flying toy is a slow flying glider that is kept aloft and maneuvered by the air currents that flow around your body as you walk. More information can be obtained by writing to:

**Tyler MacCready Enterprises**  
P.O. Box 3578  
Simi Valley, Ca. 93063-3578

---

---

## NEWS FROM SWEDEN

---

---

Surprise, Boomerang World! There is an active boomerang organization at the north end of Europe; somewhat in isolation, but that can be fixed, can't it. Ola Wahlberg made a trip to the USA last summer, made contact with the D.C. throwers and returned to Sweden with the goal of bringing our clubs closer together. The **Swedish Boomerang Club** publishes an excellent newsletter titled: "Returbladet". The president of the SBS is Pontus Bjorck. Kjell Carlsson and Hans Petersen edit, compose and distribute Returbladet to SBS members. Rutger Staaf is a supplier of boomerangs for SBS members. The English language contact is Johannes Schoon. He can be reached at the following address:

**Johannes Schoon**  
Box 1024  
43621 Askim  
Sweden

The following excerpt, written by Johannes Schoon is taken from the August 1988 issue of "Returbladet":

*I often get irritated when the myth about the boomerang's flight: "They can send a man to the moon, but can't explain the flight of a boomerang" pops up in a conversation. As a student, I can report to all yee with little faith that the laws that govern the motion of a boomerang are alive and in good health, in spite of their age. I have to admit that analytical solutions are attainable only for rather simple problems. The mathematician Felix Hess, who with skill and a primitive computer from the 60's, reconstructed flight paths of the boomerang (It can be done again and better, but it would cost some bones). By the way, the old myth of the nonflying bumble-bee was exterminated by science some decades ago.*

---

---

## NEWS FROM FRANCE

---

---

Jacques Thomas writes to tell us of the "Fourth International Boomerang Days" held in Bievus, outside of Paris in September. Twenty five competitors from Scotland, England, Germany, Belgium, Holland and France participated in the gathering. The winner of the event was Michael Frohlich from West Germany, shown holding the handsome prize cup in the photo, center column. Jacques Thomas applauds in the background.

Ten members of the LaPerouse family belong to the French based "La Perouse Boomerang Club". Jean Francois de La Perouse is the *French James Cook*, who explored Australia in the eighteenth century. A new ship in the French Navy bears his name. The club will offer a boomerang to the captain of the new ship at official ceremonies in Brest this year.

A museum was officially opened at La Perouse, Botany Bay, Australia, in February 1988. The French Minister for Defence, Andre' Giraud, participated in the ceremonies. He was presented a boomerang made by John Timbery as a gift from Marjorie Timbery, John's wife. John is the brother of the famous Aboriginal boomerang craftsman: Joe Timbery, who died in 1978. The Timbery family is descended from the tribes that lived in the Botany Bay region when La Perouse first arrived in Australia. John &

Marjorie Timbery (pictured below) were invited to visit France in June, 1988.

Jacques Thomas and Denis Lemaitre met John and Marjorie at a cocktail party held in their honor in Paris. The party was hosted by Kodak and included a slide presentation featuring the discovery of Australia. A few days later, They met the Timberys in Albi (Southern France). The party toured the castle of Go, native house of La Perouse, and threw boomerangs in the front yard. This climaxed the trip by returning a visit made by La Perouse more than two centuries before.

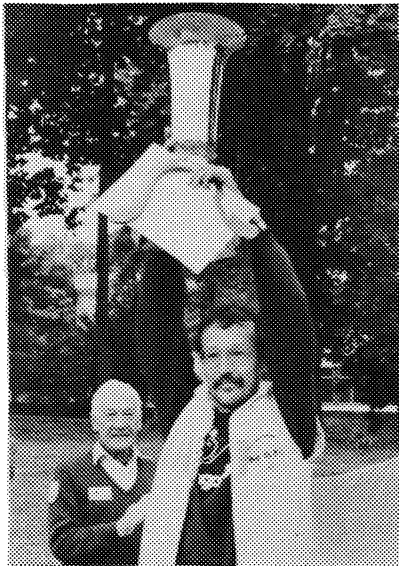

**Michael Frohlich wins the Cup**



**John & Marjorie Timbery at the Castle of Go**

---

---

## NEWS FROM BRAZIL

---

---

Carlos Martini Filho is the founder of the **Bumerangue Clube do Brazil** based in Sao Paulo, Brazil. He writes: "My interest in boomerangs started seven years ago when he accidentally broke a young girl's boomerang in the Ibirapuera Park. I was so upset when I tried to make a new one for her with no success. A Brazilian (Portuguese) literature search provided no information on boomerangs, so I carefully experimented until I met with success several months later. During that period of time, the bank that I worked at failed (things like that happen in Brazil) leaving me without a source of income. I made contact with Dr. Pagliuchi (MHR, #34) and began making and selling boomerangs down in the park. I now have a small shop with seven workers and give free lessons in the park. The Bumerangue Clube do Brazil was started to allow others to experience the emotions I experienced when throwing a boomerang. I want to bring the various local throwers together and organize competitions. That is not easy in Brazil because most people are more interested in Football (Soccer). I am interested in hearing from other clubs for suggestions on rules and how to organize competitions. I would also like to have an experienced competitor visit us to help us in this task. I am interested in trading some of my fine boomerangs for boomerangs from other countries. If you are interested in helping our club, please write to the address below":

**Carlos Martini Filho**  
**Caixa Postal 13.074**  
**01.000 Sao Paulo, SP**  
**Brazil**

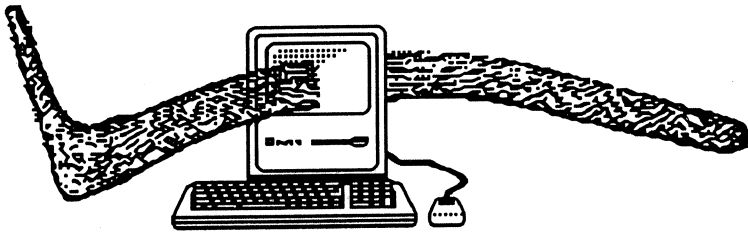

## BOOMERANGS & COMPUTERS

This issue of MHR contains three computer programs written by German boomerangers. Each is similar because they design boomerangs based on a family of shapes which include an elbow that is composed of concentric circular arcs and arms that are straight in length with circular tips. The geometry, not unlike the phenomenal strip-laminated fast catch boomerangs made by Doug DuFresne, is depicted on page 9. The first program, listed on pages 8 & 9, was written by Gerhard Bertling who published the boomerang flight path generating program in the summer issue of MHR. The next two programs, listed on pages 10 through 14 were contributed by Klaus "Dabbes" Dabelstein. Hats off to these two generous boomerang designers for unselfishly sharing their work with the readers of MHR. Hopefully they will benefit readers with access to a home computer.

## BOOMERANG DESIGNER

by Gerhard Bertling

The Boomerang Designer computer program designs "super symmetrical" boomerangs (U - type). This type of boomerang is defined as one where the elbow section is circular and eccentric relative to the center of mass.

Input Data includes: Inner radius of elbow section (RI) ; Width of arms ( T ) & Angle between the arms (A). The program draws the calculated shape and prints (after a keypress) the additional data: Outer radius (RA) ; Tip-to-tip span (S) ; Height (H) ; Center-of-tips coordinates relative to the center of mass ( Y , +/- X ). These boomerangs fly very nice with stable rotation. But do they fly better than other booms? I don't know. Another German Engineer, "Dabbes" (Klaus Dabelstein) has written a similar program which was published in "Bumerangwelt" and the BBS newsletter.

---



---

### BOOMERANG DESIGNER PROGRAM by GERHARD BERTLING

---

```

1  REM *****
2  REM *
3  REM *          BOOMERANG DESIGNER          *
4  REM *          written by                  *
5  REM *          Gerhard Bertling           *
6  REM *          May 1987                   *
7  REM *
8  REM *****
9  HOME
10 INPUT " WIDTH OF ARMS? " ; T
20 INPUT " INNER RADIUS? " ; RI
30 INPUT " ANGLE BETWEEN ARMS? " ; A : W = A * 3.14159 / 180
35 HGR : HCOLOR = 3
40 RA = RI + T
50 YA = RA * SIN ( W / 2 )
60 YI = RI * SIN ( W / 2 )
70 XA = SQR ( RA ^ 2 - YA ^ 2 )
80 XI = SQR ( RI ^ 2 - YI ^ 2 )
85 MA = - XA / YA : MI = - XI / YI : BA = RA ^ 2 / YA : BI = RI ^ 2 / YI
86 S = 0
90 FOR Y = RA TO 0 STEP -.2
100 IF Y > RI THEN X1 = 0 : GOTO 130
110 IF Y > YI THEN X1 = SQR ( RI ^ 2 - Y ^ 2 ) : GOTO 130
120 X1 = ( Y - BI ) / MI
130 IF Y > ( YA ) THEN X2 = SQR ( RA ^ 2 - Y ^ 2 ) : GOTO 150

```



```

140 X2=(Y-BA)/MA
150 S=S+Y*(X2-X1)
155 GOSUB 1000
160 NEXT Y
170 S2=0 : S3=S2
180 XK=X2-T/2*COS(W/2)
190 YK=- (T/2*SIN(W/2))
200 K=2*YK
210 FOR Y=0 TO YK-T/2 STEP -.2
220 IF Y>K THEN X1=(Y-BI)/MI : GOTO 240
230 X1=XK-SQR((T/2)^2-(Y-YK)^2)
240 X2=XK+SQR((T/2)^2-(Y-YK)^2)+XK
250 S2=S2+(X2-X1)*Y : S3=S3+(X2-X1)
260 NEXT Y
270 Y=-.2
280 X1=(Y-BI)/MI : X2=(Y-BA)/MA
290 S=S+Y*(X2-X1)
300 GOSUB 1000
310 IF S > ABS(S2+Y*S3) THEN Y=Y-.2 : GOTO 280
320 XK=X2-T/2*COS(W/2) : YK=YK+Y : K=K+Y
330 H=Y-.2 : FOR Y=H TO YK-T/2 STEP -.2
340 IF Y>K THEN X1=(Y-BI)/MI : GOTO 360
350 X1=XK-SQR((T/2)^2-(Y-YK)^2)
360 X2=XK+SQR((T/2)^2-(Y-YK)^2)+XK
370 GOSUB 1000
380 NEXT Y
390 GET A$ : REM WAIT
395 TEXT : HOME
400 PRINT " ARM-WIDTH      = " ; T
410 PRINT " ANGLE          = " ; A
420 PRINT " INNER RADIUS    = " ; RI
430 PRINT " OUTER RADIUS     = " ; RA
440 PRINT " SPAN              = " ; INT(20*(XK+T/2)+.5)/10
450 PRINT " HEIGHT            = " ; INT(10*(T/2-YK+RA)+.5)/10
460 PRINT " CENTER OF TIPS AT " ; -INT(10*YK+.5)/10 ; " BELOW ... "
470 PRINT "                   AND " ; INT(10*XK+.5)/10 ; " TO THE ... "
480 PRINT "                   LEFT/RIGHT ..."
485 PRINT "                   FROM CENTER OF MASS "
490 END
1000 M=4 : YP=70-M*Y
1010 HPLOT M*X1+140, YP TO M*X2+140, YP : HPLLOT 140-M*X1, YP TO 140-M*X2, YP
1020 RETURN

```

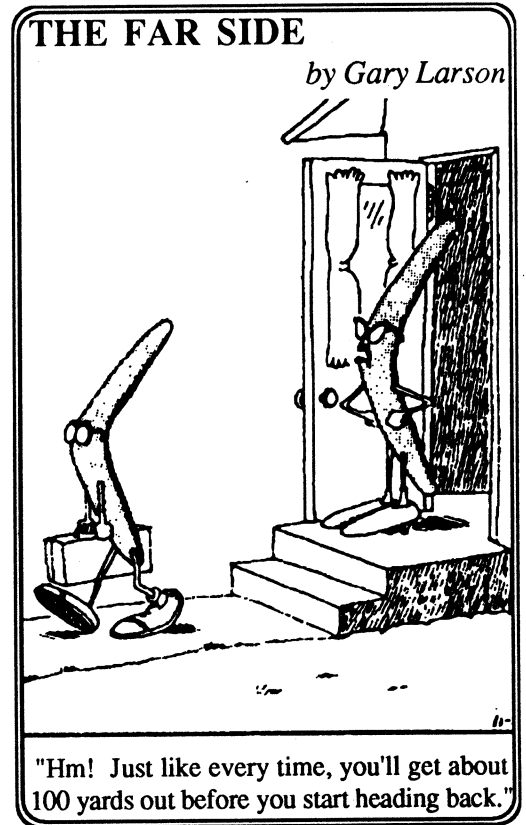

## SAMPLE OUTPUT FOR BOOMERANG DESIGNER

```

uRUN
WIDTH OF ARMS ? 3.5
INNER RADIUS ? 8
ANGLE BETWEEN ARMS ? 50
ARM-WIDTH = 3.5
ANGLE      = 50
INNER RADIUS = 8
OUTER RADIUS = 11.5
SPAN       = 36.1
HEIGHT     = 25.2
CENTER OF TIPS AT 11.9 BELOW ...
                AND 16.3 TO THE ...
                LEFT/RIGHT ...
                FROM CENTER OF MASS

```

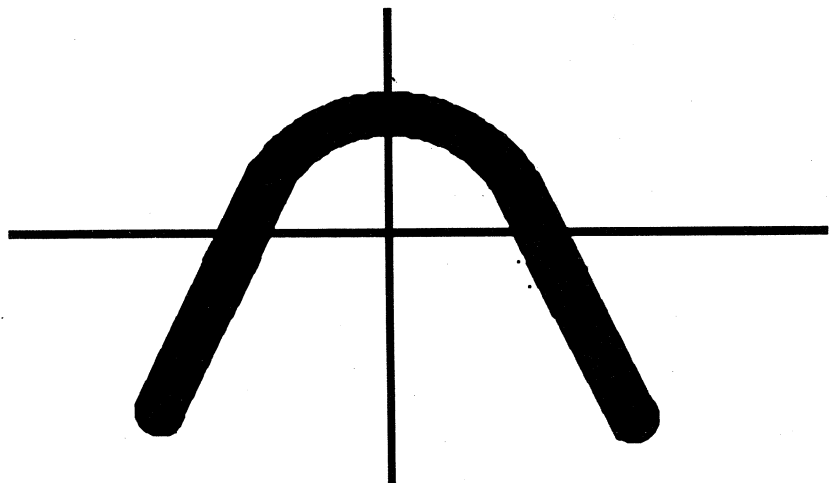

# COMPUTER DESIGNED BOOMERANGS "DABBES' DEFINITION"

by Kl. H. "dabbes" Dabelstein

If you are bored copying all the boomerangs you have found in literature and you experience a temporary blackout with your imagination; here is another way to design a boomerang: let your home computer do it!

## Idea

In order to create a simple mathematical model of a boomerang, divide it into three parts: the elbow and the two adjacent arms. The elbow is part of a ring (ABAB) & the arms are rectangular areas (ABED). It is now possible to design the boomerang in such a way that the centre of gravity (S, cog) - the centre of rotation - is identical with the centre of the part of the ring (S). This is done so that during rota-

tion, the elbow has no disturbing aerodynamic influence. The peripheries (inner & outer) are identical to the streamlines during rotation. In order to solve the mathematical problem, the inner & outer radii and the boomerang angle must be preset. It is then required that the arm length be determined so that the cog of the elbow is balanced by the cog of the arms.

## Solution

There are two different solution techniques: (1) calculation or (2) using a boomerang balancer. Al Gerhards' boomerang balancer as described by Rusty Harding in earlier literature could be used on all kinds of boomerangs. I use two simpler boomerang balancers as they are for use only on "dabbes' definition" boomerangs. One is a razor blade, and the other is a loop of fine cord. Referring to the sketch below, if the boomerang is supported at point B by a razor or a hanging loop of cord, and the line AB stands vertical: then the boomerang is well balanced, because point B, the cog of the boomer-

rang and the cog of the earth are colinear. The calculation method is quite different. Using the BASIC computer program which follows, you can input the two radii and the following information is output for a range of included angles (refer to the sample printout): profile ratio, arm length, span, total area, weight, radius at the blade tips, area contributing to lift during rotation, weight divided by lift area, weight divided by total area and a rough estimate of the moment of inertia.

## Remarks

Because of the assumptions made by the analysis, a slight error in the weight estimate is made, necessitating implementation of slightly longer arms or the addition of weights.

## Summary

The name "dabbes' definition" was chosen because the boomerang is defined by Physical relationships. The program that follows reinforces the fact that balancing is only part of the design process.

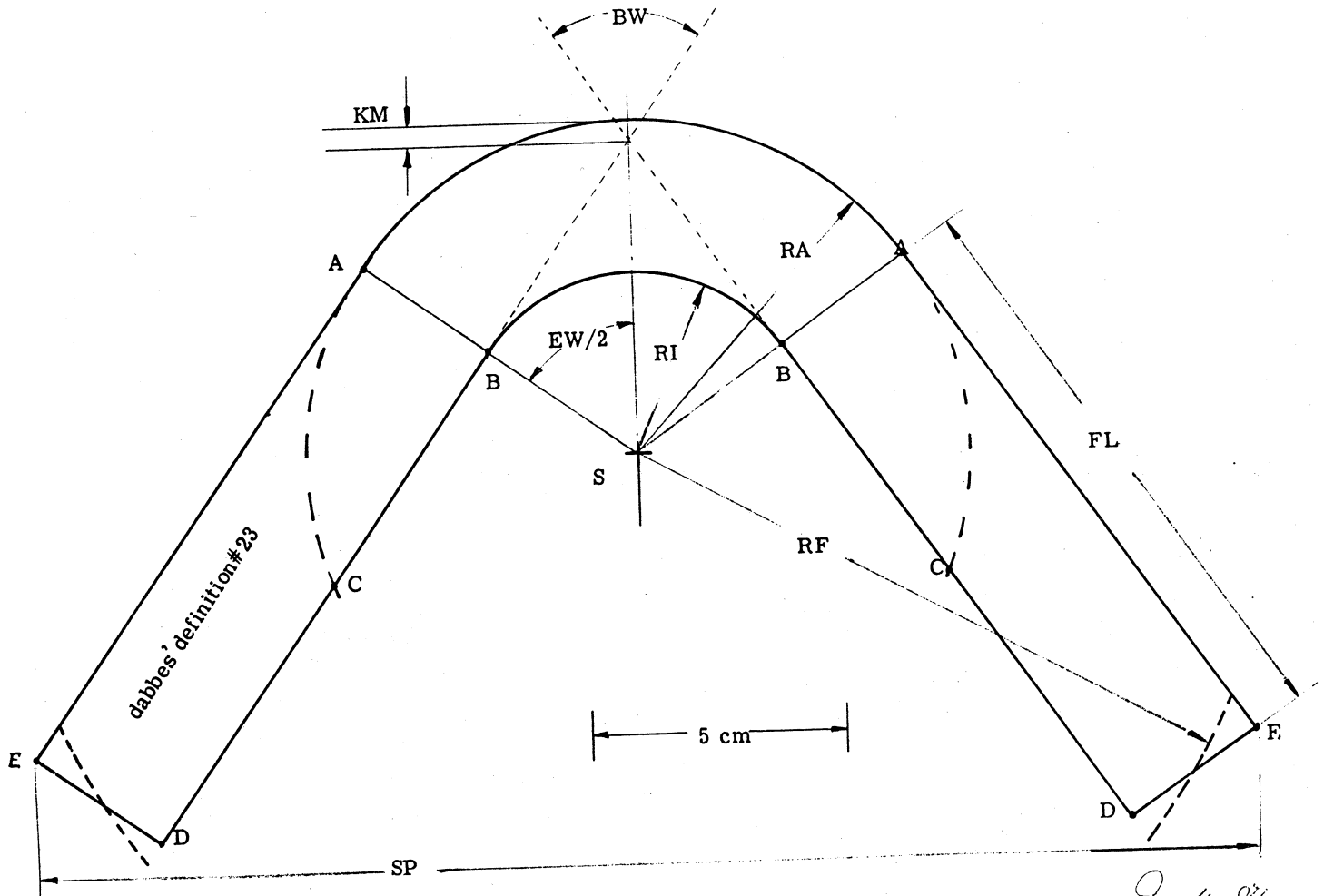

## SHORT DESCRIPTION OF THE BASIC PROGRAM "dabbes' definition"

### Computer Compatability

This program has been run on several different computers over the past year, using different dialects of the basic computer language, all without problems.

The program execution time can be quite different, depending on the kind of computer used. The shortest time was experienced on the IBM PC using Turbo-Basic: 2 sec. The time can be more than 30 seconds using a Commodore DC64 or C128. Two computer programs are provided. **Beidru**, the first program, prints design data for a single case. **Bumdru**, the second program, prints tabulated data for a range of included angles.

### Line Description of Bumdru:

050-090: input of radii & thickness  
 120-190: printout of headline  
 210-220: data calculations  
 280-330: calculation of arm length  
 340-390: more data calculations  
 400-500: output printing  
 540-560: tables of sine & cosine

### Abbreviations

AG : total area of boomerang ( $\text{mm}^2$ )  
 AAT  $2 \cdot \text{EDAC}$  : lifting surface area  
 BR , AB : width (mm)  
 BW : angle between the arms  
 EW : angle of elbow (degree)  
 F0 : calculated minimum arm length  
 FL , AE : arm length (mm)  
 GA : ratio of mass and total area  
 GW : mass (gm)  
 KC : cosine  
 KM : temporary variable  
 KS : sine  
 MD : thickness (mm)  
 PV : ratio of profile  
 RA , AS : outer radius of elbow (mm)  
 RI , BS : inner radius of elbow (mm)  
 RO : density ( $\text{gm}/\text{cm}^3$ )  
 RF : radius at end of arm (mm)  
 SE : ratio of mass to total area  
 SP , EE : theoretical span (mm)  
 THM : moment of inertia ( $\text{kg} \cdot \text{cm}^2$ )

### Remarks

Both the weight and the moment of inertia are dependent on what is preset for density. The value currently preset in the programs is an average measure of several 5mm Finnish birch plywood sections.

The calculated moment of inertia is an analytical approach that closely approximates the dynamic moment of inertia. The calculated values are essentially identical to values measured on actual boomerangs. Details are available on request.

Don't mix up your 0 (zeros) and O (letter Ohs) when entering variable names. RO uses the letter "O" and F0 and V0 use the number "0".

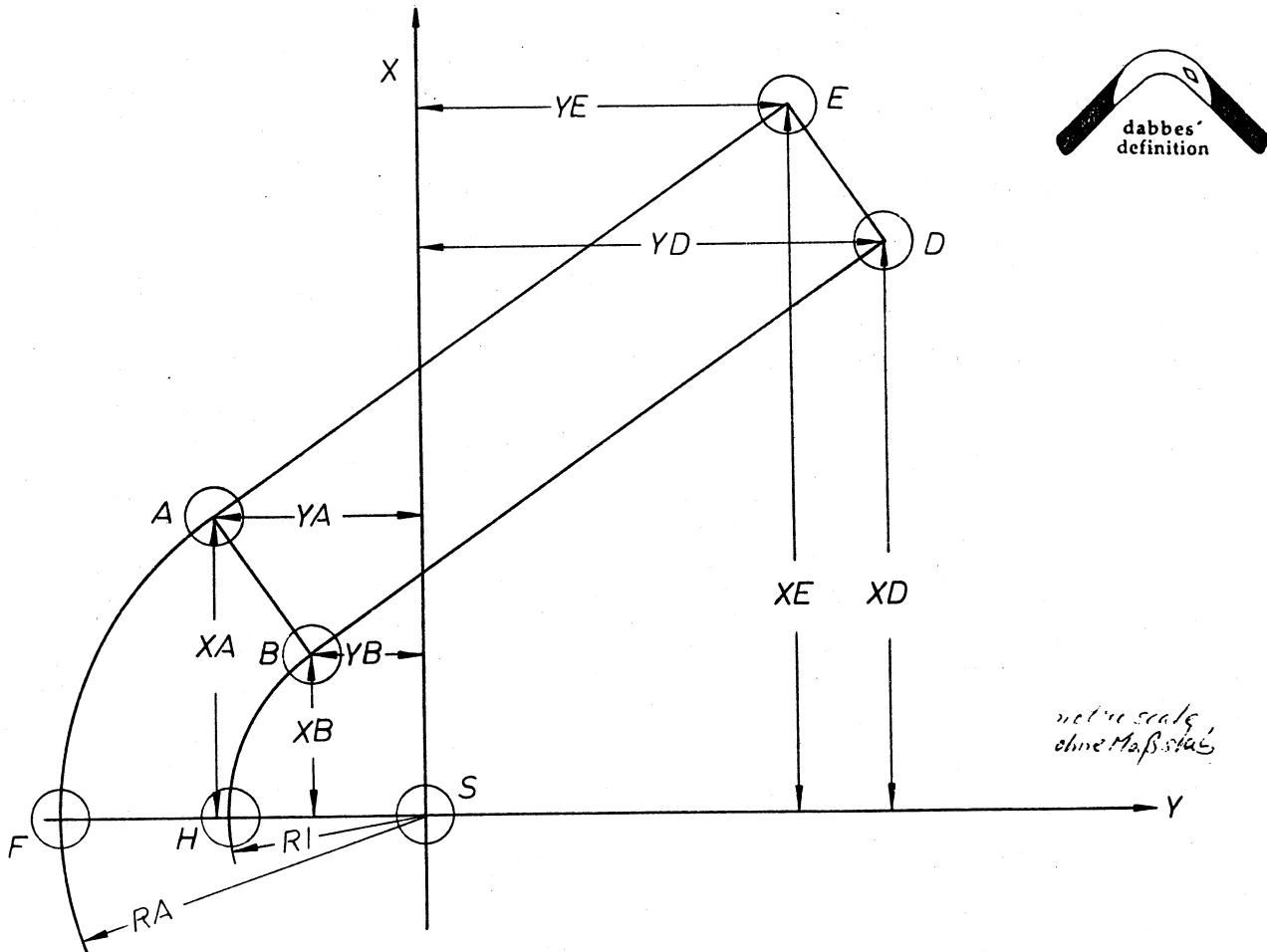

**BASIC PROGRAM: BEIDRU ; version 100288**

```

10 REM BUMERANG DABBES' DEFINITION VERSION 100288 NAME : BEIDRU
20 INPUT " Boomerangle : " ; BW
30 INPUT " Inner Radius : " ; RI
40 INPUT " Outer Radius : " ; RA
50 INPUT " Thickness : " ; MD
60 PV = (RA - RI) / MD ; RO = .78
70 PRINT
80 BR = RA - RI : RM = RA - BR / 2 : DFQ = RA ^ 2 - RI ^ 2 : Y1 = .6666 * (RA ^ 3 - RI ^ 3) / DFQ
90 R1 = RA ^ 2 : R2 = RM ^ 2 : DB = RO * MD
100 EW = 180 - BW : ARS = EW * DFQ * .008727
110 KS = SIN (.01745 * EW / 2) : KC = COS (.01745 * EW / 2)
120 FO = RM * TAN ((90 - EW / 2) * .01745)
130 Y0 = Y1 * (114.592 * KS) / EW : Y2 = RM * KC : S = 2 * RA * KS
140 FOR FL = FO TO 500 STEP .1
150 AFL = BR * FL : Y3 = .5 * FL * KS : H2 = Y2 - Y3
160 Y4 = (2 * AFL * H2 + ARS * Y0) / (2 * AFL + ARS)
170 IF Y4 > -.1 AND Y4 < .1 THEN 200
180 FO = FL
190 NEXT FL
200 SP = 2 * FL * KC + S : AG = (ARS + 2 * AFL) / 100 : GW = DB * AG * .1
210 KM = RA - RI / KC : RF = SQR (R2 + FL * FL)
220 AR = .5 * R1 * (EW * .01745 - SIN (EW * .01745)) / 100
230 AT = 2 * AFL / 100 - AR : GA = GW / AT : SE = GW / AG
240 RS = SQR (R2 + (FL / 2) ^ 2) : T1 = DB * (ARS * (Y0 ^ 2) + 2 * AFL * (RS ^ 2))
250 TH = 1.1 * T1 * 10 ^ -8
260 LPRINT " dabbes' definition "
270 LPRINT
280 LPRINT " boomerang angle          BW  deg  : " ; LPRINT USING " ###.## " ; BW
290 LPRINT " Inner Radius                    RI  mm  : " ; LPRINT USING " ###.## " ; RI
300 LPRINT " Outer Radius                     RA  mm  : " ; LPRINT USING " ###.## " ; RA
310 LPRINT " Thickness                          MD  mm  : " ; LPRINT USING " ###.## " ; MD
320 LPRINT " Width / Thickness                 PV  : " ; LPRINT USING " ###.## " ; PV
330 LPRINT " Density G / CM ^ 3                RO  : " ; LPRINT USING " ###.## " ; RO
340 LPRINT " Arm length                        FL  mm  : " ; LPRINT USING " ###.## " ; FL
350 LPRINT " Span                               SP  mm  : " ; LPRINT USING " ###.## " ; SP
360 LPRINT " Total area                         AG  cm ^ 2 : " ; LPRINT USING " ###.## " ; AG
370 LPRINT " Lifting area                      AT  cm ^ 2 : " ; LPRINT USING " ###.## " ; AT
380 LPRINT " Propeller radius                  RF  mm  : " ; LPRINT USING " ###.## " ; RF
390 LPRINT " Half elbow angle                  EW/2 deg : " ; LPRINT USING " ###.## " ; EW / 2
400 LPRINT " Moment of Inertia                 TH  : " ; LPRINT USING " ###.## " ; TH
410 LPRINT " Mass                               GW  gm  : " ; LPRINT USING " ###.## " ; GW
420 LPRINT " temporary variable                KM  mm  : " ; LPRINT USING " ###.## " ; KM
430 LPRINT " Mass / lifting area                GA  : " ; LPRINT USING " ###.## " ; GA
440 LPRINT " Mass / total area                  SE  : " ; LPRINT USING " ###.## " ; SE
450 :
460 REM      KOORDINATES
470 YA = RA * KC : XA = RA * KS : YB = RI * KC : XB = RI * KS
480 XD = (RI * TAN (.01745 * EW / 2) + FL) * SIN (.01745 * BW / 2)
490 YD = SQR ((FL + RI * TAN (.01745 * EW / 2)) ^ 2 - XD ^ 2) - RI / KC
500 YE = YD - BR * SIN (.01745 * BW / 2) : XE = SP / 2
510 LPRINT
520 LPRINT "      Y      X "
530 LPRINT " A      " ; LPRINT USING " ###.## " ; YA , XA
540 LPRINT " B      " ; LPRINT USING " ###.## " ; YB , XB
550 LPRINT " D      " ; LPRINT USING " ###.## " ; YD , XD
560 LPRINT " E      " ; LPRINT USING " ###.## " ; YE , XE
570 LPRINT " F      " ; LPRINT USING " ###.## " ; RA , 0
580 END

```

**BASIC PROGRAM: BUMDRU ; version 180288**

```

10 REM BUMERANG DABBES' DEFINITION VERSION 180288 NAME: BUMDRU
20 LPRINT " dabbes' definition "
30 LPRINT
40 :
50 INPUT " Inner Radius      ":"; RI
60 PRINT
70 INPUT " Outer Radius     ":"; RA
80 PRINT
90 INPUT " Thickness        ":"; MD
100 :
110 PV = (RA - RI) / MD : RO = .78
120 LPRINT " Inner Radius      RI mm      ":";: LPRINT USING "####"; RI
130 LPRINT " Outer Radius     RA mm      ":";: LPRINT USING "####"; RA
140 LPRINT " Thickness        MD mm      ":";: LPRINT USING "####.#"; MD
150 LPRINT " Density g/cm^3    RO         ":";: LPRINT USING "####.#"; RO
160 LPRINT " Width/Thickness  PV         ":";: LPRINT USING "####.#"; PV
170 LPRINT
180 LPRINT " BW  FL  SP  AG  AAT  RF  EW/2  TH  GW  KM  GA  "
190 LPRINT " Deg mm mm cm^2 cm^2 mm Deg gm mm gm/cm^2"
200 LPRINT
210 BR = RA - RI : RM = RA - BR / 2 : DFQ = RA ^ 2 - RI ^ 2 : Y1 = .6666 * (RA ^ 3 - RI ^ 3) / DFQ
220 R1 = RA ^ 2 : R2 = RM ^ 2 : DB = RO * MD
230 FOR BW = 50 TO 130 STEP 5
240 EW = 180 - BW : ARS = EW * DFQ * .008727 : READ KS , KC
250 IF BW <> 50 THEN 270
260 F0 = RM * TAN ((90 - EW / 2) * .01745)
270 Y0 = Y1 * (114.592 * KS) / EW : Y2 = RM * KC : S = 2 * RA * KS
280 FOR FL = F0 TO 500 STEP .1
290 AFL = BR * FL : Y3 = .5 * FL * KS : H2 = Y2 - Y3
300 Y4 = (2 * AFL * H2 + ARS * Y0) / (2 * AFL + ARS)
310 IF Y4 > -.1 AND Y4 < .1 THEN 340
320 F0 = FL
330 NEXT FL
340 SP = 2 * FL * KC + S : AG = (ARS + 2 * AFL) / 100 : GW = DB * AG * .1
350 KM = RA - RI / KC : RF = SQR (R2 + FL * FL)
360 AR = .5 * R1 * (EW * .01745 - SIN (EW * .01745)) / 100
370 AAT = 2 * AFL / 100 - AR : GA = GW / AAT : SE = GW / AG
380 RS = SQR (R2 + (FL / 2) ^ 2) : T1 = DB * (ARS * (Y0 ^ 2) + 2 * AFL * (RS ^ 2))
390 TH = 1.1 * T1 * 10 ^ - 8
400 LPRINT USING "####.#"; BW ;
410 LPRINT USING "####.#"; FL ;
420 LPRINT USING "####.#"; SP ;
430 LPRINT USING "####.#"; AG ;
440 LPRINT USING "####.#"; AAT ;
450 LPRINT USING "####.#"; RF ;
460 LPRINT USING "####.#"; EW / 2 ;
470 LPRINT USING "####.#"; TH ;
480 LPRINT USING "####.#"; GW ;
490 LPRINT USING "####.#"; KM ;
500 LPRINT USING "####.#"; GA ;
510 NEXT BW
520 LPRINT
530 LPRINT " Weight / Total Area gm / cm^2      ":";: LPRINT USING "#.##"; SE
540 DATA .9063 , .4226 , .887 , .4617 , .866 , .5 , .8434 , .5373 , .8192 , .5735 , .7934 , .6087
550 DATA .7661 , .6428 , .7373 , .6756 , .7071 , .7071 , .6756 , .7373 , .6428 , .766
560 DATA .6088 , .7933 , .5737 , .8191 , .5373 , .8434 , .5 , .866 , .4618 , .887 , .4226 , .9063
570 END

```

### Sample output for program: BEIDRU

Boomerang angle	BW	deg	: 105						
Inner Radius	RI	mm	: 50						
Outer Radius	RA	mm	: 90						
Thickness	MD	mm	: 5.0						
Width / Thickness	PV		: 8.0						
Density G / CM ^ 3	RO		: 0.78						
Arm length	FL	mm	: 226.6						
Span	SP	mm	: 469		A		Y	X	
Total Area	AG	cm^2	: 218		B		71.4	54.8	
Lifting area	AT	cm^2	: 167		D		39.7	30.4	
Propeller radius	RF	mm	: 237		E		98.3	210.2	
Half elbow angle	EW/2	deg	: 37.5		F		66.6	234.6	
Moment of Inertia	TH		: 14.5				90.0	0.0	
Mass	GW	gm	: 85						
temporary variable	KM	mm	: 27.0						
Mass / lifting area	GA		: 0.51						
Mass / total area	SE		: 0.39						

### Sample output for program: BUMDRU

Inner Radius	RI	mm	: 50
Outer Radius	RA	mm	: 90
Thickness	MD	mm	: 5.0
Density gm / cm ^ 3	RO		: 0.78
Width / Thickness	PV		: 8.0

BW	FL	SP	AG	AAT	RF	EW / 2	TH	GW	KM	GA
Deg	mm	mm	cm^2	cm^2	mm	Deg		gm	mm	g/cm^2
50.0	137.9	280	174	50	155	65.0	5.5	68	-28.3	1.37
55.0	143.0	292	176	59	159	62.5	5.8	68	-18.3	1.15
60.0	148.4	304	177	69	164	60.0	6.2	69	-10.0	1.00
65.0	154.2	318	180	79	169	57.5	6.6	70	-3.1	0.89
70.0	160.4	331	182	89	175	55.0	7.1	71	2.8	0.80
75.0	167.3	347	185	99	181	52.5	7.7	72	7.9	0.73
80.0	174.7	363	189	109	188	50.0	8.4	74	12.2	0.68
85.5	183.0	380	193	120	196	47.5	9.2	75	16.0	0.63
90.0	192.0	399	198	131	204	45.0	10.1	77	19.3	0.59
95.0	202.2	420	203	142	214	42.5	11.3	79	22.2	0.56
100.0	213.6	443	210	154	225	40.0	12.7	82	24.7	0.53
105.0	226.5	469	218	167	237	37.5	14.5	85	27.0	0.51
110.0	241.2	498	227	182	251	35.0	16.8	89	29.0	0.49
115.0	258.3	532	238	197	268	32.5	19.8	93	30.7	0.47
120.0	278.2	572	252	215	287	30.0	23.8	98	32.3	0.46
125.0	301.8	619	268	236	310	27.5	29.2	105	33.6	0.44
130.0	330.2	675	289	260	338	25.0	37.0	113	34.8	0.43

Weight / Total Area gm / cm ^ 2 : 0.39

---

## PERRY TOURS THE USA

---

Roger Perry of Norseman, Western Australia completed a two month whirl-wind tour of the USA this summer, visiting friends, competing in tournaments, giving demonstrations, and touring cities that he always wanted to visit.

The first two weeks were spent in Ohio with Ted Bailey, Aaron Ackerman, Gary Broadbent, and Chet Snouffer. This provided ample time to get acquainted with sizzling Mid-West early August temperatures. This was quite a shock after leaving an all time record low temperature of -4 C in Western Australia only a few days before.

The first week included a warm-up demonstration at a Cystic Fibrosis Children's Camp on the South Shore of Lake Erie. the next few days were spent making Bailey style F/C and MTA booms and adjusting to the reverse Coriolis Force in the Northern Hemisphere in preparation for the Delaware and Cleveland Tournaments.

The second week included the two tournaments and some time with Chet & Carmen before visiting Aaron Ackerman & family on their lovely farm setting in Central Ohio. Then a few days with Gary Broadbent and up to Detroit to a demonstration at the Cranbrook Institute of Science.

The next stop was in St. Louis, staying with Tom Fitzgerald and family. A work shop and demonstration was held in 99% humidity and 106 F temperatures that made a round of fast catch feel like a round of endurance.

Heading south to cooler weather, Mickey Kinley played host for a few days and long distance (120 metre +) throwing of Mickey's famous Boomalums was the order of the day. Another stop in Florida to Ed Pieratte and family to visit with the throwers of the Tallahassee Boomerang Club. Finally a sight seeing trip to New Orleans and Baton Rouge before heading into the wilds of Louisiana to visit with the Boomerang Man, his wife Jean, and many of the local throwers. Then back to New Orleans to catch a plane to St. Louis for their first annual tournament. Saying goodbye again to St. Louis, the last leg of the trip began on the West Coast.

The first stop on the West Coast was with Jerry Caplan's family and local throwers. It was here that Roger tried driving a car on the right side of the road for the first time in his life, scaring some of the throwers and oncoming cars as he merged into traffic on the wrong side of the road. The next stop was at the DuFresne's in Portland, Oregon to get ready for the annual Summer's Last Fling Tournament which had the only enjoyable competition weather of the entire tour.

Following the tournament, Roger rented a car and drove to Vancouver, Canada for some sight seeing before returning to Portland for some white water canoeing with Doug & friends. From Portland, it was on to LA for a day before flying off to sunny Hawaii for a few days of rest and relaxation. Finally, with funds exhausted, it was back home to Australia.

Roger Perry plans on another visit to the USA in 1989, hopefully as part of an Australian team which may compete in the Third Annual International Team Cup. Roger thanks all those individuals who responded so favorably to the announcement of his trip in MHR with offers to host and entertain him while he was here. Perhaps Roger will meet new friends on his 1989 tour of the USA. Anyone wishing to purchase his fine line of competition products can contact the Boomerang Man from the advertisement within this issue.



**Roger Perry, Champion Thrower from Western Australia**

---

**Many Happy Returns**

---

---

## TEAM GEL'S CONNECTICUT BOOMTEST

---

---

by Mole Man

The day (August 6) started out kind of slow with Consecutive Catch where Barnaby Ruhe, Dennis Joyce, John Flynn, and Rob Parkins all tied for first place with only 4 catches. But for the tournament they had a throw off. Dennis Joyce came in first, followed by John Flynn then Barnaby Ruhe.

The next events were Accuracy and Aussie Round. In the accuracy competition Barnaby Ruhe placed first with 25 points, followed closely by 15 year old Sarah Myers with 24 points. Barnaby was sweating bullets.

In Aussie Round, Barnaby won with 65 points followed by John Flynn with 61 and Rob Parkins with 52.

Mike Darnell took Doubling with 11 catches. Jim Jordan was next with 9 and John Flynn with 8.

Light winds blew our MTA's and gave us some exercise. A few left the park, but Larry Ruhf was able to keep his in the air for 35.61 and caught 1st place. Second was Dennis Joyce with a time of 29.93 and Barnaby took third with 27.17.

Next, we had the Endurance competition. Scores weren't too high because of the winds, but everyone worked hard anyway. John Flynn took first with 38 catches....Dennis Joyce took second with 37....and Mike Forrester and Barnaby Ruhe tied for third with 33 catches.

Fast catch was another win for Barnaby Ruhe with an even 30 seconds. He was followed by Peter Ruhf with an even 32 and Jim Jordan with 34.02.

Last at the end of a long day came Juggling. You can probably guess who came in first. Barnaby made us all wait and watch while he spent 15 minutes doing an outstanding 51 juggles. Second, with still a high score of 21 was Peter Ruhf, and third was Mike Forrester with 15.

With 5 firsts, 2 thirds, and a fifth place, Barnaby accumulated a whopping 76.95 points to take first overall. In second place was John Flynn with 54.75 points, and Jim Jordan came in third with 50.50 points.

The day ended with an award ceremony, Bar-B-Que and a Rad and Knarly party where, same as the rest of the day, Radness and Good Times were demonstrated by all.

---

---

## SUMMER'S FINAL FLING

---

---

by Doug DuFresne

The tournament was held in Portland, Oregon on September 18. As in the previous three years, the weather was great for boomeranging.

In the first event, Matthias Giesenschlag of West Germany led the way with a 40 in Accuracy. Betsylew Miale, Dennis Joyce (surprise visitor from the East) and Steve Kavanaugh tied for second with 34 points each.

In the next event, Fast Catch the top 3 places were 29.43, 29.46, and 29.55 sec. in shifty breezes by Doug DuFresne, Dennis (Juice) Joyce and Matthias, respectively. That's close!

Juice won Consecutive Catch handily with 16 catches. Steve Kavanaugh made 11. Roger Perry of Western Australia made 10 to finish 3rd.

By the time MTA<sub>100</sub> started, the breeze was up and erratic. Several throws were well over a minute (and out of bounds). Tom Peterson, a local boom maker who makes some great MTA's, had a 1 1/2 minute flight that landed at the 30 meter line after he missed the catch. He ended up 3rd with 34.49 seconds. Juice won with 38.09, and DuFresne took 2nd with 37.14. On his 5th MTA throw, Juice completed a round of Fast Catch before catching his 35 second MTA flight.

Awards for all the novice and team events and the complete veteran events were then presented. The hard core throwers and necessary officials remained for the less spectator-oriented events.

DuFresne, the first thrower of Australian Round, set the pace with 76 points using a 30 meter boom. Juice, not sure enough of his 30 m boom went for 40 m but lost more accuracy points than Doug. He matched the 76 for a 1st place tie. Steve Kavanaugh was 3rd with 72 points.

Roger Perry and Doug tied to win Juggling with 9 catches. Will Gix and Juice took 3rd with 8 catches.

Roger Perry, making up for lost time, showed us how to Double with a recently acquired Doubling set from Chuck Smith/Chet Snouffer. He made 17 catches to win. Juice was 2nd with 10, and DuFresne and Jeff Asher tied for 3rd with 5 catches each.

Matthias Giesenschlag, not to be for-

gotten, made 56 catches in the allotted 5 minutes to win Endurance. DuFresne was 2nd with 54, and Roger Perry continued his charge for the overall with 49 and 4rd place.

Dennis Joyce was the clear overall winner. He placed 1st or 2nd in all events except his 5th place in Endurance and 3rd in Juggling. Dennis had to be the sentimental favorite anyway after showing the uninitiated what Super Catch is all about. Dennis earned 71.5 placing pts.

Doug DuFresne was 2nd with 58.5. He placed in the top 3 in all but 2 events.

Roger Perry placed 3rd overall with 52.5 points. He had 2 firsts, 2 thirds, and 3 other finishes in the top 10.

4th through 10th places were earned by Steve Kavanaugh, Matthias Giesenschlag, Will Gix, Mike Krausser, Tom Peterson, Jeff Asher, and Betsylew Miale respectively.

There were 21 veterans-about half the 1987 turnout. It was a good group of competitors who turned out. This year, the field was cleared and the party started back at the DuFresne's before it got dark!

---

---

## World's Largest Boomerang Discovered

---

---

Tom Fitzgerald of the St. Louis Boomerang Club has discovered what appears to be the largest boomerang in the world. Embedded in the banks of the Mississippi River at the edge of the city of St. Louis Mo., the boomerang resembles a giant Gerhards Big "U". A photograph follows:

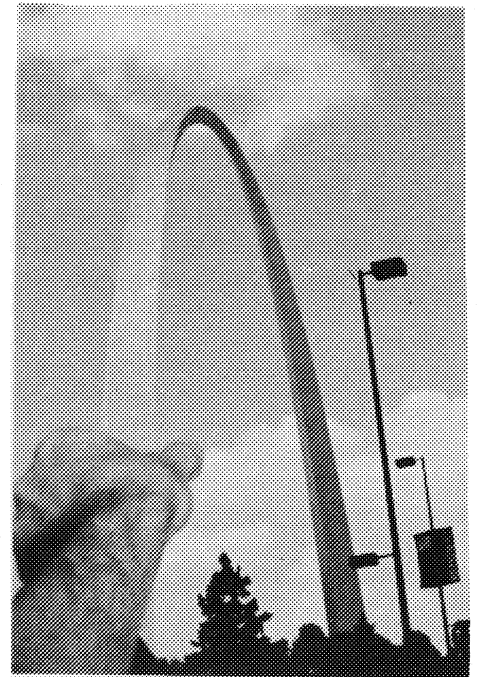



---

---

## 1988 WORLD CUP (a different perspective)

---

---

OK, you've all read the accounts of the 1988 World Cup - Australia in your MHR and Leading Edge newsletters. Here's an interesting account by Eric Darnell's better half: *Cheslea Larson*.

Well, here we were, on the other side of the planet, coming together with people from seven countries, and there was one subject of conversation. Never mind the Queen's visit to inaugurate the new Australian Parliament building, the Aboriginal demonstrations and curse on the great aboriginal mosaic outside the Parliament building, the elections in France, or Donald Regan's memoirs.

People were taping, filing, swapping and talking boomerangs. Some came with more boomerangs than others-Doug had suitcases full and learned the hard way the the Aussies impose import duties and a 25% tax on foreign boomerangs. Eric was going to keep his limited edition weapons off the market until after the matches, but couldn't resist selling a fast-catch to Yoshi, and "hot tickets" to the French-if you perceive a strategy here to hedge U.S. bets against the Aussies you may be right. (Apparently Eric also sold a boomerang to Steven Moran, and Australian medical student, who turned around and beat him in accuracy with it in the day of the individual comps). Chet's boomerangs sold out. Rod Jones appeared the night before the final match and spread out his beautifully crafted and decorated boomerangs and created what someone called a "feeding frenzy". Peter Byham had cranked out a mind-boggling quantity of his Binghi models so there were boomerangs in abundance for spectators and throwers who wanted souvenirs or something to round out their kits.

Peter and Joan (whose combined efforts were responsible for the smooth running of the whole shebang) hosted an Australian roast that featured an auction. The prize items were a Janetski boomerang that was snapped up for \$200.00 and Bob Burwell's bush hat that went for \$50.00. He said it was time for a new one: The greatest fun that night was seeing Brother Brian Thomas' films of the '81 Australian tour. It was easy to recognize Larry, Peter, Chet, Doug et al by their throwing styles (we'd know those bodies anywhere) and did a double-take of

Robby Croll's and Eric's long hair.

Throwers who were in Melbourne for a windy match in 1981 would no longer find that field. In its place is a new sports complex. We gathered there as soon as we arrived and got our first look at the other teams. This was our first taste of Australian hospitality, it was tea (was it morning tea, afternoon tea, or "regular" tea which is dinner? At this point after 34 hours of journey this traveller was too zonked to know which day it was. Forget the jet-lag diet that's supposed to put you right in synch with your destination, it may work fine for trips to Europe or Hawaii, but is useless for the antipodes.).

We were welcomed by Dennis Maxwell, his wife Claudia, and their friends and neighbors who fed us home cooked meals and put us to bed. And watched the evening news at six to see Chet doing the back flip (designed to put the Aussies on notice) and hear Barnaby rave "It's a disease-thats why we're all going out at night with our glow sticks. It's like eating potato chips!" This may have made sense to the viewers who hadn't had too many beers, but I wonder how many understood that Barnaby really is an oracle.

"Don't be shy with the Australians" said Bruce Cater's mum, "you have to talk back in self-defense!"

Well, they weren't too hard on us, and really made us feel right at home.

We were invited to Bicentennial Field Day at the local school. Saw sheep shearing, horse shoeing, bull whip demonstrations. Jackie Byham was on hand to show pieces from his collection of Aboriginal artifacts, and Rob Croll demonstrated the amazing technique of circular breathing on the diggeridoo. Jackie taught us how to hum a tune on a gum leaf but none were quick at learning that. Here all the kids were dressed up in colonial costume: many convicts, swagmen, and even a girl done up as a jar of Vegemite. The kids had Bicentennial souvenir cards and mobbed the team members for signatures. Enduring images of that day were of Yoshi: In the sack race he had some trouble keeping a hold on his sack until his feet went clean through and he hiked it up and ran. Later, in his attempts to learn to handle the bull whip, he wrapped it around his ears and flicked off his hat. Yoshi was a great favorite: adventurous, determined, and very speedy out on the field. Chet and Carmen were hanging out at the monkey bars at the center of a cluster of beautiful little girls who were to be their fans for the rest of

our stay in Barooga. They came out to the field to cheer for the Yanks and came by on bikes to visit after school. We left the picnic before the cow chip toss and the gum boot event, but not before Chet performed the back flip. Usually one hears "Does a boomerang really come back?". Here it was "Will he do the back flip?".

### MAN AND BEAST

A couple of curious events: The fellow demonstrating the bull whips (your burly, two-fisted, handy to have around the house type guy) called for the kids to volunteer their favorite teacher for a stunt. He deftly wrapped the tails of a couple of whips around the subjects chest. Fine. Then he called for the least favorite teacher, had the fellow lie prostrate with his legs apart. He put a styrofoam cup between this man's legs and proceeded to make the cup dance with his whip. Egads!

Days later we visited Jackie Byham's place. Jackie has ongoing contact with two aboriginal tribes and is their blood brother. We gathered in his extraordinary treasure house to hear stories about pieces in his collection, poled around in the workshop where he makes boomerangs and hunting sticks, and wandered about in the paddock to get a close look at his kangaroos.

One kangaroo named Boxer has the reputation of being feisty, and we were amazed to see Dennis teasing him. Boxer reared up into a sitting position, and as Dennis continued he stretched himself taller until he seemed nearly as tall as Dennis. From a safe vantage point on top of a woodpile we watched Boxer, stiff and threatening, take a swipe at Claudia, who was standing next to Dennis.

### THE BIG DEAL

We met the Swiss on the side of the road at a rendezvous north of Melbourne. Making their presence felt with their brilliant uniforms and clanging cow bells, they were like the Troubadours of boomerang. At the first two matches, there were a modest number of spectators, but we all heard Peter Byham declare on T.V. that a crowd of 2000 had turned out. Now you can count on the Swiss cheering section for volume, which was a good thing for the other spectators-made us feel powerful. And that's how we fooled Peter.

From a spectator's point of view this tournament was the best ever. Dennis Maxwell gave an entertaining blow by blow commentary over a good sound system. Scores were relayed instantly from the judges on the field. The alternation of

teams and events kept the pace lively. All this, the keenness of the competition, and the adverse wind conditions made these games really gripping.

Part of the excitement was seeing old acquaintances like the Fast French (Oliver and Stephane), Michael Siems (who must be an expert at extracting thorns from bare feet), Mark Shafer (the Aussie team coach), and Tony Dunlap. Then there was the mystery of the unknown-the Dutch and the Japanese teams.

The big question was-could we beat the Aussies? Rob Croll has made his mark as a great competitor, but what about the other guys? Over the course of the week we came to appreciate the team we were trying hardest to beat.

Geoff Kennedy, determined and full of bounce, made great leaps and kicked up his heels coming off the field in triumphant occasions. He showed the T.V. public a diving catch that ended with a roll up onto his neck and head over heels.

Bruce Carter, solid and reserved, came through in match #3 with a blazing performance. It included a hot first round in fast catch and an animated second round after the wind blew his chance of a good score-catching under his leg and on top of his head. He also scored the only 20-point bullseye in Aussie Round for the entire tournament.

You have to know that the Australian women were a first-rate cheering squad, splendid with skirts, pom-poms, and enormous enthusiasm.

One of the pleasures of our stay in Barooga was meeting Bluey Roberts and his family, who represented Australia's Aboriginal people at the games. His Uncle Jimmy was a legendary tracker for 47 years and found 164 lost people in the course of his career. Bluey and his sons gave demonstrations of throwing hunting sticks and boomerangs and competed in the individual comps. Little Bluey took second place in accuracy (with a slotted plastic boomerang), and his other great joy was being Barnaby's sidekick. Stankly took 2nd in Fast Catch.

The PBS program "Discover the World of Science" crew filmed Bluey throwing and discussing boomerangs. This and some highlights of the 3rd World-Cup Match will probably be part of a segment scheduled for December. They may have caught the jubilation at the end of the tournament as the teams stood under their respective flags, the American received the BIG CUP, and Chet helped Geoff do the back flip.

---

---

## 1988 QANTAS PICNIC AT MT. DIABLO

---

---

by James Miller

I attended a picnic at Mt. Diablo State Park, hosted by Qantas Airlines to put on a demonstration for 600+ spectators over a twenty minute period.

I was notified that I would be throwing in a 100 yard field. "No problem" I stated, "it'll be perfect for some 60 yard 'rangs'!" I figured I'd take a few H.A. Smith paxolins, just to add a "finishing" touch too!

We arrived at Mt. Diablo around 1:00 p.m.; my cousin Ron Stevens and myself, along with a bag of 40 booms.

We had a great "steak" lunch, consumed some "Foster's", then found I had to demo in less than 30 minutes....without practice!

Now, my 100 yard field was 35 yards by 45 yards. The size of my front yard! I must admit, it is good for yard games and "tug-of-war", but for boomerangs?? But, there was no backing out now!

The field setting was as follows; an oblong field, headed North. A large hill on my right, trees and spectators on my left, another hill and gully in front and massive amounts of spectators behind, a power line 20 feet above. Oh, I had variable winds to 15 mph, changing directions all the time.

I let Ron handle the microphone/speaker system the Aussie band set up, while I set out my "short rangers"-and did some praying too.

I first lofted some "super booms", which worked well. One went over the heads of the crowd behind me. The crowd awed.

Relieved a bit, I tossed a "buzzhead", "mantis", pocket-prop", all with incomplete returns. The wind was being onery now. I lifted a "yard 'rang" and it was blown into the audience. I took a "super boom" and caught it with

two hands on the return. The crowd went wild!! I threw it again, then the wind shifted and it went to my left.....at the crowd. Someone else caught that one.

So, at my last straw and quite discouraged at the wind shifts, I brought out my last hope....a "Queen of Hearts". I lifted it with near perfect returns. I hung it on a power line once, and the wind blew it down. Now.... I went for it. A one hand catch. ON the return, I grasped for it, once, twice, three times, and caught it on the fourth grasp. The crowd loved it!! The crowd though I was toying with it, spinning it on my fingers before finally catching it.

Then a man came up from the crowd to try. He flew some "super booms" and the wind was still shifting! He couldn't get a return. A spectator yelled out "you're making him look good" I went out in front of him, some 30 yards. I told him to throw it at me. He got it close and got a near perfect return.

Now my demo came to a close as it was time for the next scheduled event.

After the picnic was over, the cars and busses nearly gone, the winds died down, I went to the parking lot..to conquer Mt. Diablo.

I pulled out a Bailey "U" and a "Boomerang Fever" and started lofting. I caught nearly ever one.

The Aussie band members came out to leave but saw me throwing. They had to try too!

Two of the band members got perfect returns and a few catches. Everyone had a swell time. And now it was time to leave.

I couldn't let them go home without some "rangs", so....I let them keep the ones they lofted earlier. Then we headed back to Sacramento!

*Editor's note: James Miller is one of the prominent throwers in the Sacramento Valley. If you are ever in the area, drop him a line at:*

James Miller  
121 Morrison Ave.  
Sacramento, Ca. 95838-3203

# USBA INFORMATION PAGE

## Many Happy Returns

Circulation: 600 Worldwide.  
Published by the:

**U. S. Boomerang Association**  
P.O. Box 182  
Delaware, Ohio 43015

**Editor/Art Director:**

Ted Bailey

**Publishing Director:**

Jim Jordan

**Advertising Director:**

John Flynn

**Mechanical Measurements:**

Image area: 9.5" deep by 7.5" wide; 3 columns to a page; width of a column: 2.25".

**Advertising Rates:**

Full Page	\$200
2 Columns	\$150
1/2 Page	\$115
1 Column	\$80
Per Column inch	\$10

10% discount for four consecutive issues. Camera-ready copy preferred. Composition billed at \$10 per hour. Publisher reserves the right to refuse any advertisement or cancel a contract without reason. Mail all advertisements to:

**John Flynn**  
RR #2 Box 209-8  
White River Jct., Vt. 05001

The deadline for advertising is approximately March 1 for the Spring issue; June 1 for the Summer issue; September 1 for the Fall issue; and December 1 for the Winter issue. Early ads with payment will receive the best placement.

### NEWSLETTER SUBMITTALS

All submittals to this newsletter should be mailed to the editor:

**Ted Bailey**  
2967 Gracewood Rd.  
Toledo, Ohio 43613

The deadline for submittals is the same as for advertising; or whenever that issue fills up. Get your articles in early. Material should include print quality art or photos. The editor reserves the right to edit all submitted materials.

### USBA VIDEO ARCHIVES

Collecting . . Editing . . Sales

**Garry Lamothe**  
18 St. James Ave.  
Easthampton, Ma.  
01027

Write for a price listing of selected titles including: historical tournament reviews, scenes from both domestic & overseas shows, scientific, and ethnographic materials, etc.

USBA information and listings are available from the USBA headquarters staffed by Chet Snouffer. For more information, contact:

**USBA**  
P.O. Box 182  
Delaware, Oh. 43015



### MEMBERSHIP INFORMATION

All membership dues should be paid directly to the membership chairman by check or money order in U.S.A. dollars. Domestic and Canadian dues are \$10 per year or \$150 for life. Overseas dues are \$20 per year or \$250 for life. Check your membership expiration date which is printed on the newsletter mailing label.

**USBA MEMBERSHIP**  
C/O Tom Tuckerman  
55 Barrett Road #333  
Berea, Ohio 44017

### USBA BOARD OF DIRECTORS

**President**

Dennis Joyce  
44 Lucinda Ct.  
Hampton, Va. 23666

**Vice-President**

Chet Snouffer  
51 Troy Road  
Delaware, Ohio 43015

**Treasurer**

John Flynn  
R.R. #2 Box 209-8  
White River Junction, Vt. 05001

**Secretary**

Tom Tuckerman  
55 Barrett Road #333  
Berea, Ohio 44017

**Directors**

John Derden  
9 Cole Grove Drive  
Swainsboro, Ga. 30401

Jim Jordan  
11813 Silent Valley Rd.  
Gaithersburg, Md. 20878

John Koehler  
37 Dufief Ct.  
Gaithersburg, Md. 20878

Garry Lamothe  
18 St. James Ave.  
Easthampton, Ma. 01027

Betsy Miale  
8019 234<sup>th</sup> S.W. #214  
Edmonds, Wa. 98020



**USBA MEMBERSHIP  
55 BARRETT ROAD, #333  
BEREA, OH 44017  
U.S.A.**

**PRINTED MATTER**

ISSUE: 41  
Dale W. Riendeau  
PO Box 484  
Jackson, CA 95642

USBA TOURNAMENT HOTLINE  
**(619) 298-4283**

**Please Note that your USBA membership  
expiration date is printed on your mailing label.**

