

# BOOMERANGS

## Many Happy Returns

Newsletter of the United States Boomerang Association

Issue 76 Spring 1999

238

~~207~~

# meters

**Manuel Schütz of Switzerland breaks the world record for distance. Twice.**

---

*Also in this issue:* 1999 Rules Update • Remembering Carl Naylor • LD Plans • Review: Handheld Wind Meters





EDITOR

Tony Brazelton

CONTRIBUTIONS

Many Happy Returns thrives on contributions from its subscribers. Please share your experiences with your fellow boomerang enthusiasts.

Payment for articles published is US\$0.02 per word after editing. Payment for images (photographs, original artwork, etc.) published is US\$1.00 per square inch (6.45 cm²) after resizing and cropping.

All contributions may be submitted by e-mail to usba-pr@usba.org

or by fax (no images by fax) to (217) 244-8371 attn: Tony Brazelton

or by mail to USBA Newsletter 2405 Lawndale Drive Champaign IL 61821

Deadlines for contributions and advertisements are published inside the back cover of every issue of MHR. Contributions will not be returned unless requested. Contributions will be considered donations unless payment is specifically requested.

ADVERTISING

The basic advertising rate is \$2 per square inch. The width of the ad must be 2.4 inches (1/3 page width), 3.75 inches (1/2 page width), 4.95 inches (2/3 page) or 7.5 inches (full page width). Ads may be any vertical length.

- Special rates per issue include:
Full page \$100 (savings of \$51.50 per issue)
Half page \$60 (savings of \$15.75 per issue)
10% discount for four consecutive issues

All advertisements must be pre-paid in USD by check or MO to USBA. The editor reserves the right to refuse any advertisement or cancel a contract without notice. The deadlines for all advertisements are published inside the back cover of every issue.

Advertisements may be submitted in any electronic format, including: Pagemaker, Quark, and Illustrator. Scan-ready hard copies are also acceptable. To make your job a little easier, we offer FREE layout and graphic design services for your advertisement. All you need to send is the text and a rough sketch of any graphics you want and WE LL DO THE REST!

Contact Tony Brazelton for more information:
USBA Newsletter
2405 Lawndale Drive
Champaign IL 61821
(217) 352-6184
(217) 244-8371 (fax)
usba-pr@usba.org

Many Happy Returns (ISSN 1524-2943) is published four times per year quarterly by the United States Boomerang Association, 2405 Lawndale Drive, Champaign IL 61821. 1999 United States Boomerang Association. All rights reserved.

1999 USBA Competition Rules

A Bold New Member-Based Direction

by John Koehler, Rules Committee Chair

Early in 1998 the USBA Board of Directors decided to revise the existing competition rules. The goal was to better reflect the latest interests and trends of U.S. Boomerang Throwers.

The first phase of the process was to form a Rules Committee (RC). A questionnaire was sent out to nominated members, asking for their views about current USBA rules, what changes they would consider and what new ideas they had. The USBA board selected the seven RC members from the completed questionnaires. The RC members were Rev. Jim Schramm, Jim Jordan, Fred Malmberg, Norm Kern, Aron McGuire, Steve Cook and John Koehler, Chair.

The second phase of the rules process was to solicit feedback from USBA members. A 4-page questionnaire was created by the RC and sent out to all members during the summer of '98. It asked for feedback about specific events, the amount of fun involved in tournaments, whether our rules should reflect the world's rules, and many other questions. The basic goal was to find out what was liked, what was not liked, and what was missing.

By early September, 35 completed questionnaires had been received by the RC, representing approximately 10 % of the membership (a very high response for direct mail).

After reviewing and compiling the results, the RC prepared a brief indicating general trends and desires in the thinking of USBA members. These trends and desires included:

- 1) The general belief that our current competition rules do a good job of measuring basic boomerang skills (catching, throwing, agility, endurance, etc.).
2) While boom tournies were fun, they could be MORE fun, and should be.
3) That boomerang tournaments in general are relatively boring and too slow, for throwers and spectators alike.
4) That certain things (such as scoring systems) should be like the rest of the world, but other things (such as Optional events) could be uniquely American.
5) That some events were considered

“holy” and should not be altered.

6) That they liked the idea of adding other events to a tournament, as long as they did not effect our ability to measure skills.

Next the RC went to work making actual proposed changes to the current rules. The proposed rules changes were presented to the USBA board in the spring of '99. An immediate discussion was launched between the RC and the board, streamlining, modifying and strengthening the proposed rules changes. The 1999 USBA Rules were approved by the USBA Board prior to this year's first tournament in Florida.

The new rules can be found online at: www.koehlerstudios.com/usbarules/RulesRC.html. Printed rules will be mailed to all USBA members.

Color Coding & Numbering System. Unchanged rules are indicated in black on the website, with new rules being shown in green, and in bold type. An easy reference numbering system is used on the rules. Scroll on the table of contents (on left) and click on the rule you wish to view, or scroll down main page (on right).

Mandatory/Optional System. The biggest format change of the new rules. Mandatory events represent the core events used in rating and general scoring, and must be completed prior to any Optional events being contested. Mandatory events are: Accuracy Australian Round Trick Catch/Doubling Endurance/Fast Catch MTA100. The new Optional Events are: GLORP Team Beaver Scramble Team Relay Team Position Team Supercatch Juggling Five-Minute Juggling Individual Relay Trial.

Notable changes to the Mandatory events include:

Accuracy. Tandem throwing is now used, where two throwers throw simultaneously (within 3 seconds of each other) from the bullseye. It was determined that this would add a fun element to the event that was least liked by the membership, while also significantly speeding it up.

Trick Catch. All throws must be made from 2m circles, with 20m range requirement. This brings Trick Catch inline with WBC (international) rules, and the other



Mandatory events, which all require some form of absolute range requirement.

**Fast Catch/Endurance.** Now a combined event, like Trick Catch Single/Doubling. Three total rounds, with Endurance as third round. Approx. 25-30 min. will be saved by this combination, due to combined warm-up period and break.

**MTA100.** Cumulative flight duration - Longest total time of best three flights combined is best. This will better measure the overall ability of MTA throwers, and will reduce the pure luck factor of the one big throw.

**International Scoring System.** Placing points are same as place. 1 pt. for 1st place, 2 for 2nd, etc. Lower scores are better. A much faster and more efficient system, and currently in use by most of the world.

The USBA hopes that these new rules will speed tournaments up, allow time for fun optional events, and add enough new and exciting elements to our core events to make them fresh and fun.

Many thanks to all those who responded. Some of the new rules are the direct result of those responses. Please feel free to respond to the editor of this publication after you have tried out the new rules. Or email John Koehler, RC Chair, at john@koehlerstudios.com. Either way, your comments are encouraged and welcome.

John Koehler  
USBA Rules Committee Chair



## PRESIDENT'S PERSPECTIVE

### Remembering Carl Naylor

by John Flynn, USBA President

In December 1997 the boomerang community lost a unique individual when Carl Naylor of Brooklyn, NY, passed away at the age of 80. Carl was instrumental in the creation of international boomerang competition as well as the creation of the USBA, serving as our first President from 1981-1983. Carl's contributions were a reflection of his character and his genuine unwavering passion for boomerangs. His interest, like many, started innocently enough, having received one as a gift, and evolved in a very different era, before specialization and before competitions, as most of us know them. His early contemporaries, had there been an international boomerang community, would have included the likes of Australians Frank Donellan, Cecil Burwell, Bluey Williams, and Les & Arthur Janetzki, and in fact he threw with the Janetzkis during trips to Australia in 1979 and again in 1981 as co-Captain, at age 64, of the first U.S. Boomerang Team.

Carl was a skilled thrower, specializing in long(ish) range throwing with large, homemade, hook-shaped boomerangs. He had deceptively strong delivery and would effortlessly throw 60-70 meters with his long arms, often with pinpoint returns in the small, sometimes crowded fields near his Brooklyn home. Carl had a great interest in teaching others about the wonders of the boomerang and often those who stopped to watch ended up with an impromptu throwing lesson. Al Gerhards recalled that in the mid-1970s, he was making large, heavy boomerangs that he didn't even consider catching. Carl helped Al refine his designs into more catchable boomerangs without sacrificing performance, and in the process the two forged a lasting friendship. Al's boomerangs, of course, have been considered classics ever since, and if you are lucky enough to throw one of Carl's big unweighted hooks, you can immediately see why he loved the long, sweeping, accurate flights they provide.

Carl's profession was as a pharmaceutical salesman and he also had interests in fine wine and a good game of chess, with the likes of fellow boomer Mike Forrester. He was a casual but keen collector of boomerangs for many years and had an interesting array of old aboriginal items and early modern Australian, American, and English boomerangs. Much of his collection was dispersed in Ted Baileys 1998 Auctions, with the proceeds placed in escrow for a TBD program Carl's estate requested to help children learn more about boomerangs.

I met Carl in 1981 at my first boomerang tournament at Amherst, and again at a demo at Yales Peabody Museum, but it was something that happened a year later that gave me a good look at the man. Following the 1983 Nationals in Fairfax, VA, a friend and I were making the long, hot return drive to VT when the fuel pump on our car gave out, just outside New Rochelle, NY. Not a place where you want to break down with only enough money for a tank of gas and no credit cards. Neither of us knew anyone in the area.

Then I remembered that Carl lived in Brooklyn. Carl knew me a bit from two Amherst contests and the Yale demo, but that was about the extent of it. We found his number through directory assistance and hoped for the best. Carl answered and after a few moments recognized who I was and agreed to come out and rescue us. About 2 hours

(continued on page 13)

stories of boomerangs, people and  
the situations they create



# Flightpaths

**"I'm sorry but we'll have to confiscate all your best beginner booms."**

**D**uring the Arctic Midnight Sun Boomerang Challenge we have to travel many times through Finnish-Norway customs to the neutral area where the camp is situated.

Last year we did it even more often than usual. The customs office is small house where customs officials usually watch TV or listen to the radio and once in a while they might look through the windows if someone is passing by. If someone actually is passing by they may wave their hand if they are in a active mood. So customs exists but you have to stop there very rarely. If you are collecting stamps to your passport you need to stop. If you are lucky, they find the stamp, but usually you end up discussing the weather, reindeer, football results or some totally irrelevant matter. And of course you have to drink a cup of coffee.

But sometimes things happen. Maybe a phone call from anonymous person who gives a tip. Maybe a call from southern customs: "We suspect that ...". Maybe a listed license plate in a black book. This might cause the officials to get up, pick up their weapons, go out and really stop somebody for some serious reason. Without a smile.

And this happened to us last day of

AMSBC.

For some

reason we

saw customs

officials standing in

the middle of the road when we were going

from Norway to Finland the last time. Three

officials with serious faces were waiting for

us at the border. "Ok, take it easy, this must

be mistake," we thought. When we stopped,

the official who was nearest walked slowly

toward our car. He walked around our car

and look carefully and suspiciously through

our car windows, especially in the backseat.

"What the h.... he's looking for?" we thought

with trembling feelings.

Finally he stopped on the driver's side

and motioned for us to roll down the win-

dow. We did it nervously, the big customs

official said in his rough voice: "Excuse me,

but you wouldn't happen to have any boo-

merangs to sell me?"

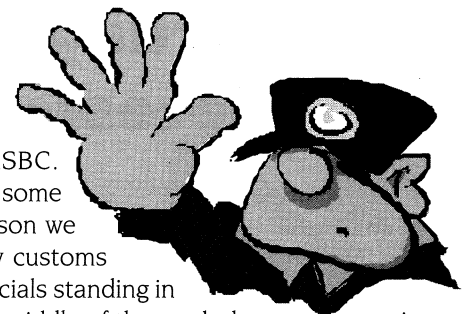

*Flightpaths* is a new MHR department devoted to human interest stories. From the inspirational to the downright silly, *Flightpaths* will give you a glimpse of the colorful personalities that help make our pas-time unique. 

Heikki Niskanen  
Kuopio, Finland

## Living at the edge

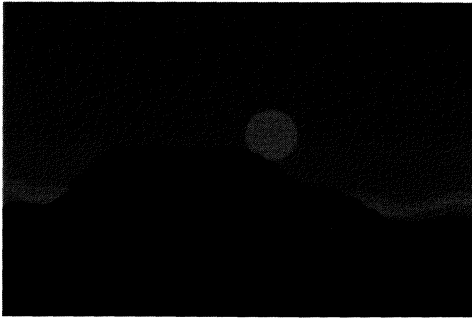

**W**hile I was on travel last week, I managed to work in a little vacation trip to see some of the Grand Canyon. Also along on the trip were my coworker and throwing partner Kevin Dennis, and our respective wives. Of course we brought some booms along to search

for unique throwing experiences.

On one of our day hikes we went down South Kaibab trail to a rest area situated a thousand feet or so down into the canyon. The rest area sits at the base of a pie shaped plateau of rock that extends out into the canyon a couple hundred yards. The view from this location is magnificent.

There were sheer dropoffs on either side of the plateau, several hundred feet in one spot, with no hope of recovering lost booms. Winds were very interesting, coming at us from the point and towards the base of the wedge of rock. As the wind came across the canyon, it would push up the rock face so that the dominant direction was *up*, any time the boom went over into open space.

We threw several different booms while we were there. The ones that worked best were those that stayed vertical through most of their flight, because the upwards wind could not lift them much when they sailed out over the abyss. Booms that flattened

out and hovered would get awesome height, my Gel *Bellen* looked more like an MTA in action.

At one point the *Bellen* came down right at the edge of the sheerest dropoff, and as much as I like that boom, I was fully prepared to let it go (the phrase "sacrifice the body" would have taken on a dramatic new meaning for *that* catch). I was relieved when it came to rest a scant one foot from the edge. Another time the wind shifted and left Kevin's Colorado *Condor* hanging out in space, where we watched helplessly as it sank below the edge. Fortunately, the trail continued down a portion of that side of the plateau in a series of steep switchbacks, and the boom drifted onto the trail below.

When all was said and done, we had enjoyed a one of a kind throwing experience in a magnificent setting.

Carl Morris  
Orlando, Florida

## Boomerangs. Dead deer. Jail. (not necessarily in that order)

Last fall, during deer hunting season, my roommate and I went to a nearby county to work for the Illinois Department of Conservation deer-checking. After the hunters had gotten a deer from the county we were in, they would bring it to us, and we would tag it, write down the age, sex, etc.

Pretty interesting stuff, really, but sometimes in the morning it would get rather dull. So, I brought a few boomerangs with me to pass the time. The location of our check-point was a county jail, and there was a really nice field right out front, with three trees at the far end.

The next thing I know I've got a boom up in a tree, and it's conveniently a tree that I can't climb, I'm about four feet short of the lowest branch, and it's smooth, so no rock climbing here. I had earlier noticed four younger kids at the other end of the field climbing the trees so I was thinking I could enlist their help and boost one of them up into the tree.

As I started to approach these kids, I said hello and three of them started yelling about not talking to strangers, and bolted, and the

fourth said hi, and then also bolted. I was impressed at the kids not talking to strangers, because when I was 12 years old, I'd talk to anyone. So, I thought nothing of it,

**I was getting worried that I was about to be arrested. I'm telling them stories about boomerangs in trees and dead deer.**

the wind picked up, started drizzling out, and so I went inside.

A little while later, three squad cars pulled onto the property, and the officers started searching the area. They were looking for someone that matched my description. They approached me, and started question-

ing me about little kids, and what I was doing here at the prison.

I was getting really worried that I was about to be arrested. This was a fairly small town, and here the police are, questioning me, and I'm telling them stories about boomerangs in trees, and dead deer, all the while standing outside the doors of a county prison. Luckily, I still had the boomerang up in the tree to prove it to them (as well as the deer checking materials).

After they saw the boomerang up in the tree, they relaxed some and explained that the children were told not to talk to anyone here, because who knows what kind of people are coming out of the county prison. Then they asked if I wanted them to have the fire department come and retrieve it. I declined, I had had enough civil service that day.

Dave Saam  
Urbana, Illinois



# SPECIAL OFFER FOR USBA MEMBERS ONLY!

## ENTER TO WIN ONE OF THESE QUALITY BOOMERANGS BY RENEWING YOUR MEMBERSHIP BEFORE JULY 9, 1999!

### HERE'S HOW :

If you are a current USBA member and you renew your membership before July 9, 1999, you can do so at the **reduced rate of \$14 per year** for as many years as you like! Also, if you renew before July 9, 1999 your name will automatically be entered into our next **prize drawing!** In the prize chest right now are:

- 1 Ola Wahlberg *DeVe*
- 1 Ola Wahlberg *Medium V*
- 9 Michael 'Gel' Girvin boomerangs (LH & RH)
- 1 100% cotton Gel Boomerangs t-shirt
- 1 Artaboo veneer indoor boomerang
- 1 Jerome Royo *Agora*
- 5 Turning Point (Eric Darnell) polypropylene *TriFlies*
- 1 Fred Malmberg Curly Oak lap joint
- 1 BetWil Boomerangs V omega with woodburn design
- 1 Tony Brazelton polypropylene Trick Catch boom
- 1 left-handed Norm Kern *Surprise+*
- 1 Greyford Co. (Tom Risher) *Winged Navigator II*
- 1 Roundtrip Boomerangs (Gregg Snouffer & Rick Tilford) traditional

Winners will be announced at the annual meeting at the US Open in Virginia Beach, Virginia. Prizes will be mailed by August 16, 1999.

**DISCOUNTED DUES! CHANCE FOR FREE BOOMERANGS!**  
**THERE HAVE NEVER BEEN TWO BETTER REASONS TO RENEW!**

Send check or money order to:  
USBA Membership  
2405 Lawndale Drive  
Champaign IL 61821

**DON'T FORGET TO  
SPECIFY RIGHT- OR  
LEFT-HANDED!**

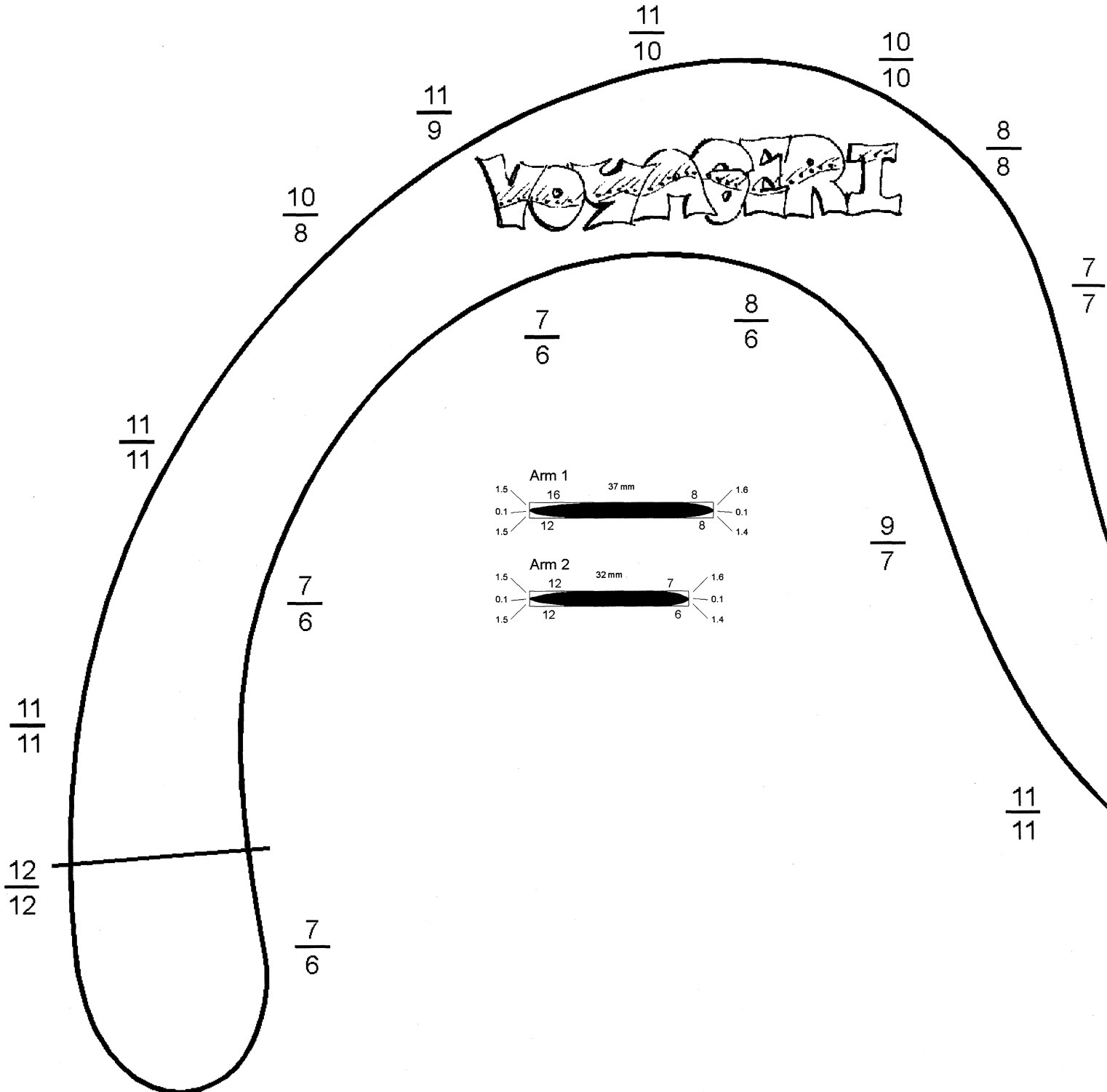



# Voyager I

Plan from the **B AGGRESSiVE** website  
[ourworld.compuserve.com/homepages/B\\_AGGRESSiVE/](http://ourworld.compuserve.com/homepages/B_AGGRESSiVE/)  
 Design by **Manuel Schütz**

This plan is for a right-handed boomerang. Use the mirror image of this plan to make a left-handed boomerang.

**Material:** 3.0 mm fiberglass laminate

**Carving:** As shown. Sand everything perfectly smooth and keep the airfoil sharp to minimize drag.

**Tuning:** Small amount (0.5-1.0 mm) of dihedral and small amount of negative angle of attack on the lift arm.

**Potential Range:** At least 238 meters.  
150 meters without the lift arm plug.

**Use:** Long Distance

**Throw:** 20° off wind, 0-5° above horizon,  
80° layover, FULL POWER!

**History:** Set the current world distance record of 238 meters by Manu in 1999.

**Scale:** 1:1

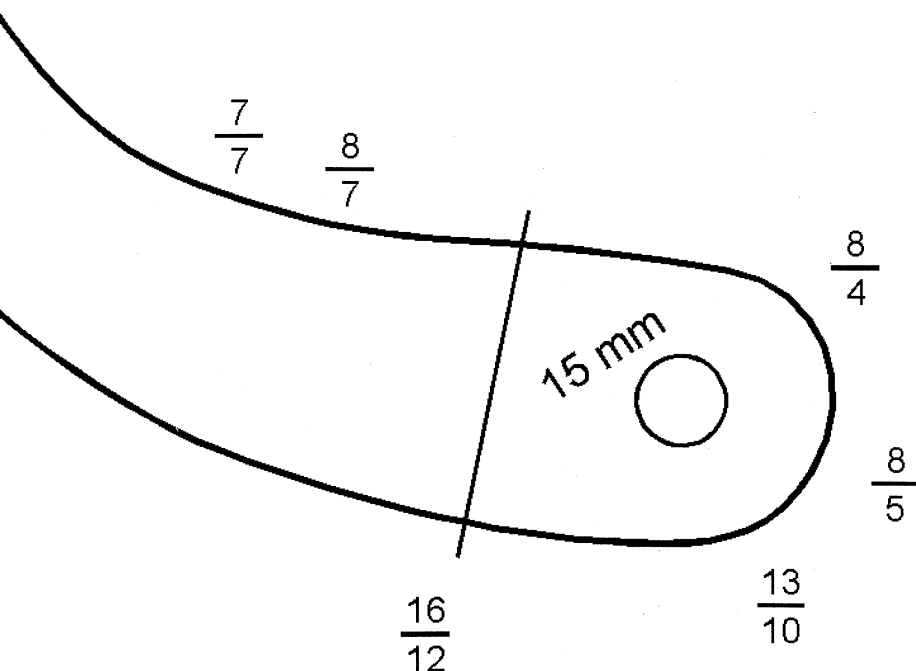

## OR JUST ORDER IT

The Voyager I can be purchased directly from Manu for 120.00 Swiss Francs (CHF) (about US\$80). Add 10 CHF for airmail delivery to overseas and 5 CHF for priority mail in Europe. International money order or Eurocheque only. Manu handcarves and tests each one individually.

**Manuel Schütz**  
**Aebnit**  
**3452 Grünenmatt**  
 phone/fax +41 34 431 23 94

# Buzz Whip

Reprinted with permission from the *BBS Journal*  
Originally published in *Swiss Boomerang Newsletter*  
Translation from German by Ivan Jeanne Weiler  
Design by David Schummy

This plan is for a right-handed boomerang. Use the mirror image of this plan to make a left-handed boomerang.

**Material:** 3.0 mm fiberglass laminate

**Carving:** Cross-section as shown is a guess but the airfoil is important.

**Potential Range:** At least 174 meters

**Use:** Long Distance

**History:** Set the world distance record of 174 meters by David Schummy in 1998.

**Scale:** 1:1

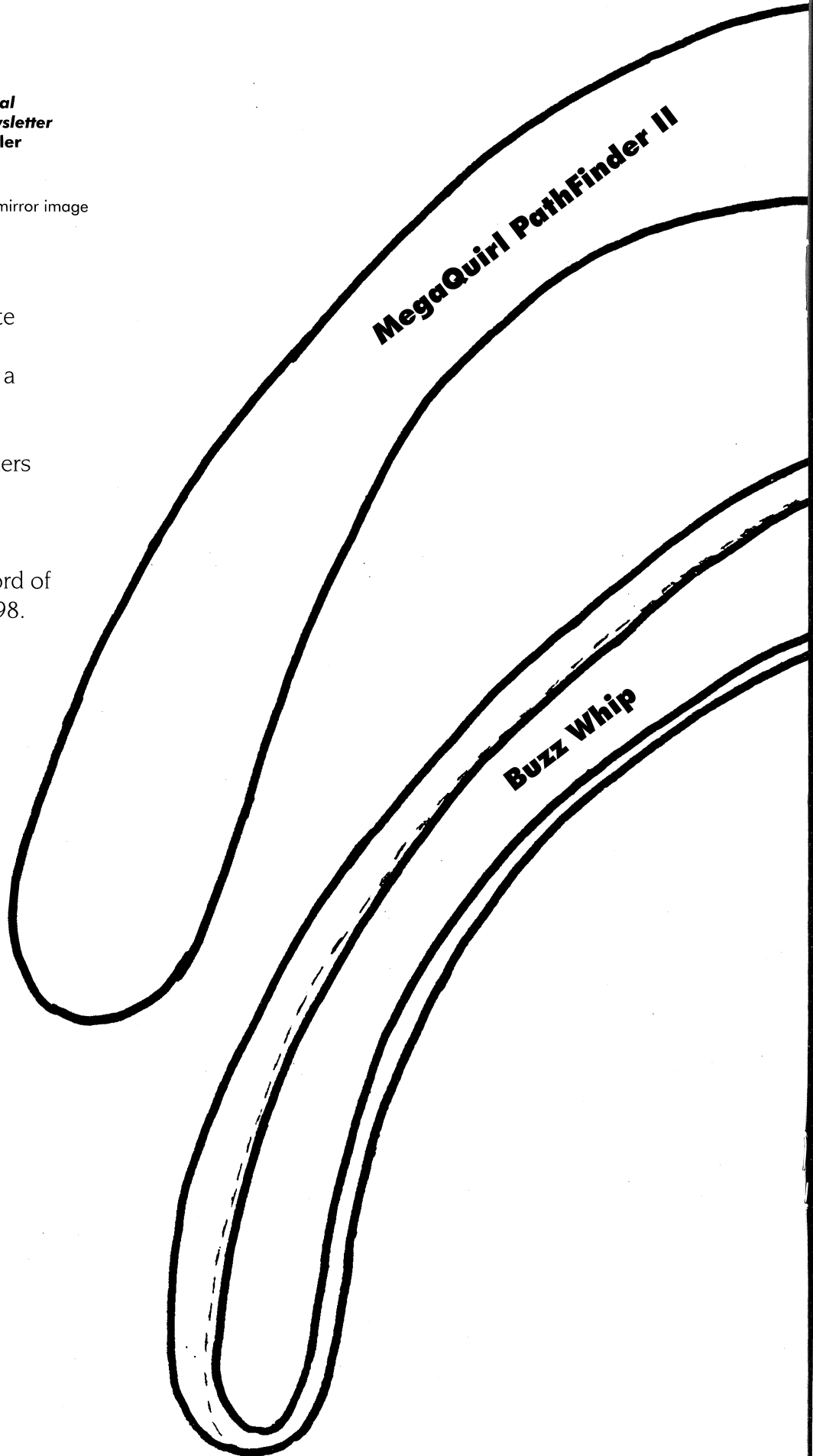
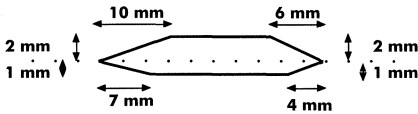

# MegaQuirl PathFinder II

Reprinted with permission from the *BBS Journal*  
Originally published in *Swiss Boomerang Newsletter*  
Translation from German by Ivan Jeanne Weiler  
Design by Manuel Schütz

This plan is for a right-handed boomerang. Use the mirror image of this plan to make a left-handed boomerang.

**Material:** 3.0 mm fiberglass laminate

**Carving:** Cross section as shown.  
Round out the airfoil.

**Tuning:** Tune it for manners and distance.

**Potential Range:** At least 207 meters

**Use:** Long Distance

**History:** Set the world distance record of 207 meters by Manu in 1999.

**Scale:** 1:1

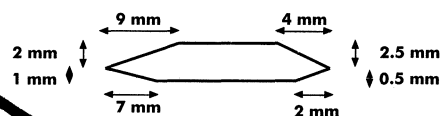

weight

# NEWS

## What is the limit?

### Manuel Schütz breaks the 200 meter mark

On May 1 in Kloten, Switzerland Manuel Schütz threw a boomerang 238 meters with full return for a new official world record in long distance.

Just days before at a distance tournament in Tentlingen, Switzerland, Schütz had smashed David Schummy's 174 meter world record with a 207 meter throw of his own. After that world record effort, Schütz had said that he thought that 220 meters might be possible. Nevertheless, he was speechless when the distance was measured and announced, "238 meters!"

In Kloten, Schütz used a modification of the Voyager I in what were described as perfect conditions (read 'steady, light breeze'). Schütz's Voyager I had a new airfoil which reduces drag and retains velocity better than the old Voyager I airfoil. The 207 meter throw in Tentlingen was made with a MegaQuirl.

Schütz is consistent. At Tentlingen he threw 192, 207 and 201 meters. At Kloten, Schütz heaved one 212 meters before his 238 meter throw in the second round.

In distance competitions, the boomerang must be thrown from behind a line

stretched between two poles 40 meters apart. The boomerang must return through the poles. Distance is marked by visual triangulation and the distance is measured with a laser range finder or tape.

Schütz's throw landed just two meters behind the line. Flight time was 22 seconds.

More information about nearly every aspect of long distance can be found at the source of LD info on the web, B AGGRESSiVE, [ourworld.compuserve.com/homepages/B\\_AGGRESSiVE/](http://ourworld.compuserve.com/homepages/B_AGGRESSiVE/).



## 1998 Financial Summary

January 1, 1998 through December 31, 1998

Compiled by Gregg Snouffer, 1998 USBA Treasurer

### INFLOWS

|                             |                |
|-----------------------------|----------------|
| Auctions                    | 2436.14        |
| Interest on checking        | 294.27         |
| Membership dues             | 2265.00        |
| Tournament sanctioning fees | 485.00         |
| USBA store                  | 153.04         |
| US Team loan payback        | 687.99         |
| <b>Total inflows</b>        | <b>6321.44</b> |

### OUTFLOWS

|                       |                |
|-----------------------|----------------|
| Insurance             | 1200.00        |
| Newsletter            | 2801.70        |
| Office                | 615.00         |
| Postage               | 732.96         |
| <b>Total outflows</b> | <b>5349.66</b> |

## NOTICE TO FOREIGN NEWSLETTER EDITORS

As of November 1, 1997, all foreign newsletter editors participating in the MHR newsletter exchange program should be sending their newsletters to USBA Newsletter, 2405 Lawndale Drive, Champaign IL, 61821, USA.

The BBS Journal, Käyräkkö, FBA Newsletter and DBC Info have graciously complied. If you are in charge of the mailing list for any of the other foreign boomerang association publications and you have not already done so, please begin sending your publication to the new address. We appreciate your cooperation in this matter.

Likewise, if you are a member of the foreign newsletter exchange program and your MHR is not being sent to the proper address, please contact me and I will make the necessary changes.

Tony Brazelton  
MHR editor



# BOOM fragments

^ Ted Bailey has moved his popular online boomerang resources, including "Boomerang World" to [www.flight-toys.com/boomerangs.htm](http://www.flight-toys.com/boomerangs.htm).

^ The France Boomerang Association has a new website at [www.multimania.com/franceboomerang](http://www.multimania.com/franceboomerang).

^ The Hopla Boomerang Club has a collection of over 90 unedited boomerang plans by French boomsmiths at [www.multimania.com/hoplabc/plans.htm](http://www.multimania.com/hoplabc/plans.htm).

^ Plans for the 2000 World Cup in Melbourne are going smoothly and progress updates can be found at [www.fixaframe.com.au/worldcup.htm](http://www.fixaframe.com.au/worldcup.htm).

^ Chris Walcott and Michael 'Gel' Girvin have added a new "throwing and tuning boomerang section" to the Gel Boomerang Information Site at [www.gel-boomerang.com](http://www.gel-boomerang.com). There are tips about how to tune and flap Doublers, how to tune MTA boomerangs, how to approach freestyle catching, how to practice, and more.

(continued on page 13)

## M. H. Rchives

*The who, what, when, where, and how of yesteryear*

### 5 Years Ago

"Three world records were set at the first Arizona tournament, held in Phoenix on October 16. First, Michael Girvin started the sequence by setting a new world record in Doubling (new USBA rules) with 17 catches. Then, Will Gix, with a score of 91, broke the world record score of 90 points in Australian Round, previously set by Brother Brian Thomas nearly 10 years ago.

Will's record was short-lived though. Only a few minutes later, Mark Weary scored an incredible 92 points to take first place in the event and the current world record mark. Both Will and Mark were using the Aussie Round boomerang *Phenolic Sunshine* made by Michael Girvin."

MHR #57 Winter 1994

### 10 Years Ago

"The Rules Committee is spending the Holiday Season fine tuning the rules for 1989. Items that the committee are addressing include 'clean' catches for Consecutive Catch and Doubling. Also under consideration are 'count-up' formats for the above two events. This would allow each competitor to throw a certain number of times regardless of any drops, and the total score (for example: 8 out of 12) would be their score. In the case of ties for top score, the surviving throwers would go to the familiar single elimination format now used in Consecutive Catch and Doubling, where, if you drop, you are 'out'."

MHR #37 Winter 1989

## Previous Design Contest Winners Lost in the Shuffle

Have you won a previous USBA Boomerang Design Contest? Do you know someone who has? We need your help to remind us who you are (we forgot to write it down).

Dave Hendricks of Allentown, Pennsylvania is acquiring a database of winners of past USBA-sponsored boomerang design contests. Since the USBA has not kept the appropriate archives, Hendricks has volun-

teered to do the research necessary to make sure that past and future winners are remembered for their contributions to boomerang art and design.

The USBA has held a design contest in conjunction with every US Open (or national championship) for many years. If you have any information about the winners of any of these design contests, please contact

**Dave Hendricks, 1086 E. Gordon St., Allentown PA 18103. E-mail: [bvdrangs.enter.net](mailto:bvdrangs.enter.net).**

Hendricks' up-to-date efforts can be found on his website at [www.fortunecity.com/marina/trinidad/123/winners.html](http://www.fortunecity.com/marina/trinidad/123/winners.html).



# REVIEW

## GEAR

### The Answer is NOT Blowing in the Wind

by Chet Snouffer

I have long been an advocate of knowing the wind speed when I'm practicing so that I can note which boomerangs perform best in those conditions. I have found that every boomerang has a certain threshold of wind within which they perform best and a point at which the wind becomes either too strong or too light for that boom to perform best. At that point, another boom either becomes a better performer or it's time to fly a kite!

I made up a chart for each event and I note the wind speed in ranges of 1-3 mph, 4-7, 8-12 and 12 and up. Within each box I then pencil in which boomerang(s) perform the best in that wind range for me. When I get to a tournament, a quick read of the wind and a glance at the chart helps me decide which boom or booms to practice with. While my competition is searching for the right stick, I have already made my choice and am using the timed warm-up

confident that the boom in my hand is the best for the conditions.

Of course, the starting point for this type of practice is knowing the wind speed. You can estimate the wind for free or spend over \$100 for a hand-held anemometer as well as everything in between. Here's a quick overview of what's on the market.

Under free, you can pretty easily estimate the wind using the Beaufort scale and watching trees, flags in the wind and the wind's effects on other objects to "guesstimate" the wind speed. The Beaufort scale is listed

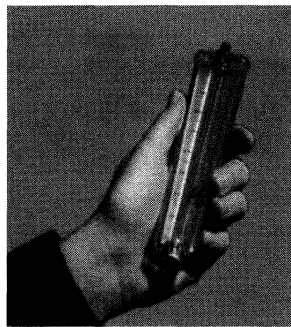

Dwyer Wind Meter \$17.90



Kestral Wind Meter \$98

in any weather book and in many kite books, as well as an encyclopedia. This least expensive system is also the least accurate as you can tell by

talking to any boomerang thrower who was blown out at the last tournament: "It was gusting to, like, 45 mph during MY round and then it dropped to, like, 4 or 5 for Adam's fast catch round. I couldn't believe it!" Neither can we!

The *Dwyer Wind Meter* is the next step up and uses air pressure and a floating ball to measure wind speed. This "pitot tube" anemometer uses the principle that as air speed over the top of the tube increases, so does the the air pressure and the ball rises to show you the wind speed. Light and easy to transport, the price is right at around \$17.90. Downsides: dirt or moisture in the tube can compromise accuracy quickly. Still, a good bargain and better than estimating on your own.

The *Kestral Wind Meter* comes in two versions. One with wind speed only (around \$98) and one with wind speed and temperature (around \$125), which also computes wind chill. Since most of our throwing is done in moderate conditions, I find the temperature feature interesting but unnecessary. The *Kestral* measures current wind speed, but will also show you average and maximum wind speed during any measured

(continued on page 13)

## Buy Yourself a Bullseye

*Where to get your own handheld wind doo-dad.*

### Into the Wind

1408 Pearl St  
Boulder CO 80302  
(800) 204-5483

*Kestral and Dwyer wind meters, plus booms and the world's best selection of kites.*

### Wind and Weather Catalog

PO Box 2320  
Mendocino CA 95460  
(800) 922-9463

*Kestral and Davis products, as well as others not listed here.*

### Davis Instruments

3465 Diablo Ave  
Hayward CA 94545-2278  
(800) 678-3669

[www.davisnet.com](http://www.davisnet.com)

## Carl Naylor

(continued from page 2)

later, around 10 PM, Carl pulled up in his utilitarian Chevy sedan and I cant tell you how happy we were to see him.

As we drove back through New York City, we talked about the Nationals, boomerangs, the car, and home. Then the topic came to food. Have you ever tried Yemenese food? No, but it sounded good. ANYTHING sounded good; we were pretty low on our hierarchy of needs, down to Shelter and Food. Carl treated us to one of the tastiest meals that I can recall under any circumstances and around midnight we arrived back at his apartment where we spent the evening. The next morning, Carl fed us breakfast, gave us a quick tour of Brooklyn, and drove us all the way back out to where the car sat. He waited until we arranged for a truck to tow the car to a repair shop, then we thanked him profusely and we went our separate ways. The car ultimately was fixed and we arrived home about 24 hours late.

I last saw Carl at Umass for the 1992 Nationals and the reunion of the original 1981 US Boomerang Team, and we had a good laugh over that experience. For those of you who never met Carl Naylor, I hope this provides a brief glimpse as to what kind of person he was and why he chosen to be the USBA's first president. Carl, thanks again.



## Anemometers

(continued from page 12)

interval. Waterproof, small and lightweight, this is my "pick of the litter". Accurate to +/-3% (ie +/- 1.5 mph at 50 mph), the Kestral is cool.

Also out there: Davis instruments makes the super-cool *Weather Wizard* and *Weather Monitor* weather stations for your home or office. They also have two hand-held wind speed indicators. The *Wind Wizard* (\$48) uses no batteries and works well, while the *Turbo Meter* (\$165) is a bit pricey, though very accurate and uses sapphire bearings.



## Boom Fragments

(continued from page 11)

Eric Darnell and Turning Point, Inc. have a new e-mail address and new fax number. E-mail [tpi@together.net](mailto:tpi@together.net). Fax (802) 765-4436.



# TOURNAMENT SCORES

**Kitty Hawk Kites South Tampa Bay  
Boom Season Kickoff  
Bradenton, Florida  
March 27, 1999**

**Trick Catch:** Steve Kavanaugh 84, Carl Morris 60, Jason Smucker 43. **Accuracy:** Steve Kavanaugh 28,

Kevin Dennis & Scott Barrett 25. **Fast Catch:** Steve Kavanaugh 20.34, Tim Maultsby 27.05, Mike Barrett 34.39. **Endurance:** Scott Barrett 45, Carl Morris & Steve Kavanaugh 38. **MTA100:** Scott Barrett 92.32, Steve Kavanaugh 88.84, Jason Smucker 75.99. **Australian Round:** Carl Morris 50, Steve Kavanaugh 42, Mike Barrett 37. **OVERALL:** Steve Kavanaugh 9.5, Scott Barrett 17.5, Carl Morris 21.5, Jason Smucker 27, Kevin Dennis 31.5, Tim Maultsby 32, Mike Barrett 37, Larry Hiller 50, Dan Hellenberg 53, Jeff Sullivan 57. **OVERALL NOVICE:** Braden Bradford 4, Timmy Hofmeister 5.



For 15,000 Years  
The Multiwing Company

S T E P H A N E  
M A R G U E R I T E  
is proud to announce that  
Walla'B is now one of the  
North American retailers  
of the European  
boomerang  
company  
FOX BOOMERANGS.



GET THE NEW SKYBLADER  
by Fox Boomerangs  
In polypropylene for only US\$10.  
Shipping to USA included.

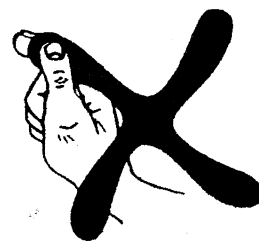

SEE THE NEW CARBON FIBER/FIBERGLASS TRIBLADER DESIGNED BY STEPHANE MARGUERITE AT OUR WEBSITE AT

[WWW.FQJR.QC.CA/BOOM](http://WWW.FQJR.QC.CA/BOOM)

CALL, WRITE OR E-MAIL FOR YOUR  
**FREE WALLA'B CATALOG**

WALLA'B  
4016 DORION  
MONTREAL, QUEBEC H2K 4B9  
CANADA

PHONE/FAX (514) 597-1333  
E-MAIL [BOOMRANG@FQJR.QC.CA](mailto:BOOMRANG@FQJR.QC.CA)

# THE USBA STORE

2405 Lawndale Drive Champaign IL 61821 [www.usba.org /USBASTore.html](http://www.usba.org/USBASTore.html)

## How to Order

Place orders by sending check or money order to the address above. Prices include shipping to US and Canada.

### Overseas Clients

Add US\$2.00 for surface and US\$4.00 for airmail. Pamphlets and back issue newsletters are US\$1.00 extra for surface and US\$2.00 extra for airmail.

All proceeds from the USBA store go into the general USBA treasury. Your purchases subsidize the US Store, *Many Happy Returns*, and insurance premiums for the USBA among other expenses.

### Questions?

Phone  
**(217) 352-6184**  
or e-mail  
[usba-pr@usba.org](mailto:usba-pr@usba.org)

## CLOTHING

◆USBA Eagle T-shirts \$12.00 members, \$15.00 nonmembers (L, XL, XXL)

## LITERATURE

◆*About Boomerangs: America's Silent Sport*, Kelly Boyer Sagert (PLANT\*Speak Publishing, 1996) \$28.00

◆Individual back issue of MHR (issues available: 26, 28, 29, 31, 32, 33, 52, 53, 57, 58, 59, 60, 61, 62, 63, 64, 65, 66, 67, 68, 73, 74, 75, 76) \$2.50

◆Get one set of ALL available MHR back issues for only \$25.00!

**Gift Certificates Available in Any Denomination!**

# USBA Member Boomsmiths and Retailers

[www.usba.org /memvend.html](http://www.usba.org/memvend.html)

Aboriginal Steve s Boomerangs  
Active Vermont  
Air Traffic Kites and Games  
Boomerangs by Ted Bailey  
The Boomerang Man  
Broadbent Boomerangs  
BVD Rangs  
Channel Craft, Inc.  
Circle Stix  
Cleveland Boomerang School  
Colorado Boomerangs  
John Cryderman  
Fly Boy Boomerangs  
Flying Frog Boomerangs  
Forever Flying  
FS Boomerangs  
Gemz  
Greyford Co. Boomerangs  
Kalmanson Boomerangs  
Leading Edge Boomerangs  
Fred Malmberg  
Master Designs Boomerangs  
Outback Boomerangs  
Rangwrights  
Rangsmith  
Roundtrip Boomerangs  
Ruhf Boomerangs  
Dan Russell  
San Francisco Boomerang School  
Stix by Steve  
Stone Mountain Boomerangs  
Turning Point Boomerangs  
WALLA B

Steve Conaway 169 Cook Drive Fillmore CA 93015  
John Flynn PO Box 4425 White River Jct. VT 05001  
M. Hedberg & L. Sandifer Mall of America Minneapolis MN  
PO Box 6076 Ann Arbor MI 48106  
Rich Harrison 1806 N. 3rd St. Monroe LA 71201  
Gary Broadbent 3204 38th St. NW Canton OH 44718  
David Hendricks 1086 Gordon St. Allentown PA 18103  
D.J. Helfer PO Box 101 North Charleroi PA  
Stuart Jones 195 E. 5th St. #605 St. Paul MN 55101  
Dave Boehm PO Box 17385 Euclid OH 44117  
407 W. Tomichi Ave. Gunnison CO 81230  
John Cryderman 136 Thames St. Chatham, ON N7L 2Y8 Canada  
Kelly Leggette 7180 Lakemond Ct. Villa Rica GA 30180  
Tom Conally 1320 Cherry Dr. Burlington NC 27215  
Shawn Donahoo 1711P Central Pkwy SW Decatur AL 35601  
Bill & Greg Schuh 9 Amethyst Dr. Murphysboro IL 62966  
Tony Gembeck PO Box 5241 Portland OR 97208  
Thomas Risher Box 4734 Whittier CA 90607  
Neil Kalmanson 766 Old Nunez Rd. Swainsboro GA 30401  
Chet Snouffer 1868 Panhandle Rd. Delaware OH 43015  
1545 E. Market St. York PA 17403  
Kendall L.Davis 932 21st Street Rock Island IL 61201  
Doug DuFresne PO Box 25577 Portland OR 97225  
John Darden 451 Colegrove Dr. Swainsboro GA 30401  
T.W. Smith PO Box 11332 Eugene OR 97440  
G. Snouffer & R. Tilford 340 Troy Rd Delaware OH 43015  
Peter Ruhf 6550 Meeting House Rd. New Hope PA 18938  
Box 84895 San Diego CA 92138  
Bill Tumath 127 Knollview Way San Francisco CA 94131  
Steve Collins 4820 Hillcrest Okemos MI 48864  
Dan Jones 222 N. Main St. Statesboro GA 30458  
Eric Darnell Star Route South Strafford VT 05070  
Stephane Marguerite 45 Pierre de Coubertin 1000 Succ. M Montreal QC H1V 3R2

(805) 524-2913 14 models for comp and fun  
802) 296-7244 boomerangs and outdoor gear  
(612) 858-9599 retailers of Colorado, Flight Stix, Gel, Outback, more  
(734) 971-2970 comp B s, newsletter, mini B s, books  
(318) 325-8157 retailer of many models, credit cards accepted  
(330) 492-RANG comp booms, demos, lesson plans & supplies  
(610) 434-7305 variety of models  
(412) 489-4900 fax (412) 489-0773 recreational woodcraft  
(612) 228-1393 demos, workshops, info phone or fax  
(216) 442-6024 variety of booms, workshops  
(800) 35RANGS recreational booms, comp booms  
(519) 354-3984 hardwood strip laminates, buyer  
(888) 213-0084 boomerangs  
(336) 584-4046 boomerangs  
(256) 308-0988 retailer of entry-level to advanced models, demos, workshops  
(618) 684-4569 SchuhFly3@aol.com Quality & economy booms  
(503) 230-8955 variety of wood B s and comp clothing  
manufacturer and distributor, buyer, retailer  
(912) 237-7831 Kalmanson reversible art boomerangs  
(740) 363-8332 comp and beginner B s, FC, doublers, more  
(717) 848-4601 rare hardwoods, lap joints  
(309) 793-9885 15 models to choose from + special orders  
beginner to comp B s, fast catch, strip laminates  
(912) 237-7831 birch ply, lap joints, poly & PVC B s, beginner to comp  
(503) 465-9461 full spectrum incl. dist., indoor, backyd, comp B s  
(740) 363-4414 whsl/retail, indoor, bkyd, beginner to comp, T-shirts  
(215) 863-3479 comp & beginner booms, specialize in lefties  
(619) 296-4243 wood booms, cyclume stix, call 4-8pm  
(415) 550-6746 Herb Smith dealer  
(517) 349-5234 beginner to comp, FC, TC, AR, art booms  
(912) 489-3640 birch ply, natural elbows  
(802) 765-4336 fax (802) 765-4436, Tri-Flies, Super-V s  
(514) 597-1333 fax same number, boomerangs

Attention manufacturers and retailers: Any USBA member who manufactures or distributes boomerangs or related products or services may be listed free of charge as a service to our members.  
Send description to: Boomsmith Listings c/o USBA 2405 Lawndale Drive Champaign, IL 61821 or fax to (217) 244-8371 attn: Tony Brazelton or E-mail [usba-pr@usba.org](mailto:usba-pr@usba.org)



# Calendar of Events

## USBA Sanctioned Tournaments

**5/29-31**

### 12th Annual Gateway Classic

Aviatoin Field, Forest Park  
St. Louis, Missouri

Missouri Duals (very fun new team format) on Saturday, USBA tournament on Sunday, throw around the arch on Monday. Contact Tom Fitzgerald. Phone: (314) 839-1604. E-mail: fitzreturn@aol.com

**6/5-6**

### 1st Annual Twin Peaks Tournament

North Bend, Washington

Immaculate polo field in view of the Twin Peaks. Fun novice events and team games followed by a salmon bake Saturday. USBA tournament Sunday. Contact Will Herlan. Phone: (425) 883-3231.

**7/31-8/1**

### 1999 US Open

Virginia Beach, Virginia

Beach boomin' at its best. Also: Design contest, lap joint contest, non-rated fun team & individual events, kylie events, auction, free food from Outback Steakhouse, and more! Contact John Koehler. Phone (757) 437-1185. E-mail john@koehlerstudios.com

**6/19**

### 19th Annual New England Boomerang Corroboree

Amherst, Massachusetts

Don't miss the second-longest running tournament this side of the Pacific. Contact

Larry Ruhf. Phone (413) 323-4340. E-mail ruhfhous@aol.com

**9/4-6**

### 5th Annual Illinois Open Champaign, Illinois

Fifth straight year of fun in the sun with perfect wind. This is Labor Day weekend so you can come for the BBQ Saturday night, stay for the tournament Sunday, and stick around for fun and games Monday. Contact Tony Brazelton. Phone: (217) 352-6184. E-mail: brazelto@uiuc.edu

To petition the USBA to sanction a tournament or other event, contact John Flynn. Phone (802) 296-7244. E-mail activermont@cyberportal.net

## Other USBA Events

**5/22**

### 10th Annual Toss Across America

A boomfield near you!

The USBA's premier grassroots effort is in its tenth year. Contact Betsy Miale-Gix to find out where is the closest TAA to you or to learn how to host your own. Phone (425) 485-1672. E-mail: bmgbooms-showdog@worldnet.att.net

**8/17-22**

### US Team Trials and

## Training Camp

Emmaus, Pennsylvania

By invitation only. Contact John Flynn for details: Phone (802) 296-7244. E-mail: activermont@cyberportal.net

## Other Events in the US

**6/18**

### Summer Solstice Throw

Bryant School

Livonia, Michigan

Take advantage of the longest throwing day of the year. Contact Norm Kern. Phone (248) 645-9308. E-mail: kerntan@aol.com.

**9/12**

### 11th Annual Novice Team Tournament

Bryant School

Livonia, Michigan

Bring friends of any skill level. Emphasis on FUN! Contact Norm Kern. Phone (248) 645-9308. E-mail: kerntan@aol.com.

**11/26**

### Turkey Toss

Bryant School

Livonia, Michigan

Boomerangs & throwsticks. Contact Norm Kern. Phone (248) 645-9308. E-mail: kerntan@aol.com.

## CORRECTIONS

There were two mistakes in the 1998 Event Ratings on page 10 of the Winter 1999 issue of *MHR*. Both are in the Overall column for Aussie Round. The Total Points in that column are incorrect. The correct points can be calculated by adding up the points from the previous three columns. Also, Mark Weary and Peter Ruhf are tied and should have each received 14.5 over-

all placing points in that event. This did not affect the overall ratings.

The plan for Georgi Dimantchev's Kamtchia on page 19 of the Winter 1999 issue of *MHR* listed the scale correctly in one place, and incorrectly in another. The correct scale is 1:1.41 (71%).

# Regional Clubs and Contacts by State

[www.usba.org /clubs.html](http://www.usba.org/clubs.html)

|    |                   |  |                         |   |       |          |
|----|-------------------|--|-------------------------|---|-------|----------|
| AZ | Phoenix           | Desert Ranglers                                      | Mark Weary & Don Monroe | 4026 East Cholla Canyon Dr. Phoenix AZ 85044  | (602) | 759-3973 |
| CA | San Diego         |  | John Weigel             | 1323 La Mesa Ave. San Diego CA 91977          | (619) | 462-4379 |
|    | SF Bay Area       | Bay Area Boomerang Club                              | Michael Girvin          | 2124 Kittredge St. #61 Berkeley CA 94704      | (510) | 658-2469 |
|    | Santa Barbara     |  | Erik Fields             | 1501 Clifton St. Santa Barbara CA 93103       | (805) | 564-4840 |
|    | Santa Cruz        |  | Brad Westervelt         | Voicemail 800-286-6310, box 748               | (408) | 338-0818 |
|    | Southern          | Southern California Boomerang Alliance               | Steve Conaway           | 169 Cook Drive Fillmore CA 93015              | (805) | 524-2913 |
|    | Southern          |  | Paul W.K. Rothmund      | 533 South Hudson Apt. #1 Pasadena CA 91101    | (626) | 584-1807 |
| CO | Aurora            |  | Richard Pollock-Nelson  | 2530 S Ouray Way Aurora, CO 80013-1576        | (303) | 368-5933 |
| CT | Madison           | The Wandering Nutmeg Boomerang Society               | Paul D. Sprague         | 782 Boston Post Rd. Madison CT 06443          | (203) | 245-8211 |
|    | Shelton           | Team Gel East  | John "Moleman" Anthony  | 21 Huntington Ave. Shelton CT 06484           | (203) | 924-6735 |
| FL | Merritt Island    | Flite Stix Boom Slingers                             | Rich Surace             | 855 E Crisafulli Rd. Merritt Island FL        | (407) | 452-3963 |
|    | Orlando           |  | Carl Morris             | 2602 Breezwind Dr. Orlando FL 32839           | (407) | 859-1319 |
|    | Southwest Florida |  | Jeff Sullivan           | 1715 SE 12th Terrace Cape Coral FL 33990      | (941) | 458-5514 |
| GA | Atlanta           | Atlanta Boomerang Society                            | Frank Golder            | #2 Capitol Square rm 370 Atlanta, GA 30334    |       |          |
|    | Swainsboro        | South Georgia Boomerang Club                         | John Derden             | 131 College Cir. Swainsboro GA 30401          | (912) | 237-7831 |
| IL | Champaign         | Illini Boomerang Club                                | Tony Brazelton          | 2405 Lawndale Dr. Champaign IL 61821          | (217) | 352-6184 |
|    | Waterloo          |  | "Chicago" Bob Leifeld   | P.O. Box 242 Waterloo, IL 62298               | (618) | 939-9023 |
| MD | Rockville         |  | Jim Nieberding          | Rockville, MD 20853                           | (301) | 933-1073 |
| MI | Ann Arbor         |  | Ted Bailey              | PO Box 6076 Ann Arbor, MI                     | (734) | 971-2970 |
|    | Birmingham        |  | Norm Kern               | 1640 Haynes Birmingham, MI 48009              | (248) | 645-9308 |
|    | Lansing           | Mid Michigan Boomsling Club                          | Steve Collins           | 4820 Hillcrest Okemos, MI 48864               | (517) | 349-5234 |
| MN | Mnpls/St Paul     | Boomerang Organization Of Minnesota (BOOM)           | Stuart Jones            | 195 E. 5th St. Apt. 605 St Paul, MN 55101     | (612) | 228-1393 |
| MO | St. Louis         | St. Louis Boomerang Club                             | Tom Fitzgerald          | 1159 Holly River Dr. Florissant, MO 63031     | (314) | 839-1684 |
| NM | Albuquerque       | Sandia Boomerang Club                                | Steve Sanders           | 10408 Woodland, NE Albuquerque, NM 87111      | (505) | 294-8842 |
| OH | Ashland           |  | Dwight Souder           | 453 Parkwood Dr. Ashland, OH 44805-4135       | (419) | 281-4565 |
|    | Canton            | Gary Broadbent's Boom Shop                           | Gary Broadbent          | 3204 38th St. NW Canton, OH 44718             | (330) | 492-RANG |
|    | Columbus          | There And Back Again Boomerang Club                  | Bob Lackey              | 31 E Dodridge Columbus, OH 43202              | (614) | 263-6840 |
|    | Delaware          | Free Throwers Boomerang Association                  | Chet Snouffer           | PO Box 664 Delaware, OH 43015                 | (740) | 363-8332 |
|    | Delaware          | U.S. Head to Head Boomerang Tournament Organization  | Gregg Snouffer          | 340 Troy Rd. Delaware OH 43015                | (740) | 363-4414 |
|    | Euclid            | Cleveland Boomerang School                           | Dave Boehm              | PO Box 17385 Euclid, OH 44117                 | (216) | 289-6324 |
| OK | Oklahoma City     |  | Joel Bussey             | 1516 Southern Heights Ave. Norman, OK 73072   | (405) | 447-2117 |
|    | Bartlesville      |  | Steven Graham           | 924 Yale Drive Bartlesville, OK 74006         | (918) | 333-0730 |
| OR | Portland          |  | Tim Schallberger        | 4740 SW Hamilton St. Portland, OR 97221       | (503) | 241-9618 |
| PA | 610 area code     |  | Dave Hendricks          | 1086 E Gordon Street Allentown, PA 18103-2208 | (610) | 434-7305 |
| TN | Knoxville         | Boomerang Club at the University of Tennessee (BCUT) | David Martin            | 2912 McNutt Avenue Maryville, TN 37804-2537   | (423) | 687-3179 |
| TX | Houston           | Boomerang Association of Texas                       | Greg Corum              | 3233 Magnum Rd. Apt 184 Houston TX 77092      | (713) | 681-0837 |
|    | Tyler             |  | Pat Steigman            | Tyler TX 75703                                | (903) | 581-5556 |
| UT | Sandy             | Wasatch Boomerang Club                               | Jim Miller              | 2095 E. 10095 South Sandy, UT 84092           | (801) | 942-6943 |
| WA | Redmond           |  | Will Herlan             | Redmond WA 98052                              | (425) | 883-3231 |

In the next issue of

## Many Happy Returns

SUMMER

1999

\* **A really interesting feature story (somebody send me something please !)**

\* **Plans!**

\* **Tournament reports**

\* **Much, much more!**

Submit your materials **now** for inclusion in the Summer issue of *MHR*. See inside back cover for details.



# the **United States Boomerang Association**

## GENERAL INFORMATION

The USBA is a non-profit organization whose goal is to promote the art, craft, sport and poetry of boomerangs through events, competitions, and information distributed through the quarterly newsletter, *Many Happy Returns*.

## USBA BOARD OF DIRECTORS

### President

John Flynn (802) 296-7244

### Vice President

Fred Malmberg (717) 848-4601

### Treasurer

Tony Brazelton (217) 352-6184

### Secretary

Betsylew Miale-Gix (425) 485-1672

### Directors

Eric Darnell (802) 765-4336

Mike Dickson (330) 499-9848

Keith Mullinar (860) 986-6396

Larry Ruhf (413) 323-4340

Chet Snouffer (740) 363-8332

## GENERAL CONTACT INFO

### Address

USBA  
PO Box 182  
Delaware OH 43015

### Website

[www.usba.org](http://www.usba.org)

### E-mail

[usba-pr@usba.org](mailto:usba-pr@usba.org)

## MEMBERSHIP INFORMATION

USBA membership entitles you to four issues of the quarterly newsletter *Many Happy Returns*, reduced entry fees for USBA-sanctioned tournaments, discounts on plywood from Anderson Int'l., discounts on books, and early notice of special offers.

Non-USBA members may receive one free trial issue by submitting the form on the left or by visiting the website.

Check your newsletter address label for issue of expiration. Membership status inquiries should be addressed to the **Treasurer**.

## VOLUNTEER OPPORTUNITIES

Want to help out the USBA but don't want to run for a seat on the Board of Directors? The Board and its committees periodically need help stuffing envelopes, conducting surveys, writing and proofreading articles for *Many Happy Returns*, and various other odd jobs. If you would like to help out as a volunteer, feel free to contact any board member.

## MEMBERSHIP FORM

USBA members: Copy this page and carry extra copies in your boombag. Your membership is extended one issue if a new member lists you as a sponsor below.

Name \_\_\_\_\_

Address \_\_\_\_\_

City \_\_\_\_\_ State \_\_\_\_\_ Postal Code \_\_\_\_\_ Country \_\_\_\_\_

Sponsor's name \_\_\_\_\_

### Check one

- New member (payment enclosed)
- Renewal (payment enclosed)
- Trial issue (no payment required)

### Check one

- Right-handed
- Left-handed

### Dues

#### North America

Annual \$15  
Lifetime \$225

#### Outside North America

Annual \$20  
Lifetime \$350

Make checks payable to USBA

Send this completed form along with payment to:

**USBA MEMBERSHIP**  
2405 Lawndale Drive  
Champaign IL 61821

# MHR DEADLINES

Each issue of *Many Happy Returns* has a subset of themes which are relevant to the time of year that the issue is published. Persons contributing to MHR may wish to keep these themes in mind when deciding on the appropriate issue to which to submit one's writing. Please also keep in mind that contributions need not be limited to these themes. Details for submitting text and graphics can be found inside the front cover.

**WINTER** Deadline  
January 1

**SPRING** Deadline  
April 1

**SUMMER** Deadline  
July 1

**FALL** Deadline  
November 1



**United States  
Boomerang Association  
2405 Lawndale Drive  
Champaign, Illinois 61821**

**[www.usba.org](http://www.usba.org)**

**BULK RATE  
U.S. POSTAGE PAID  
PERMIT NO. 453  
CHAMPAIGN, IL**

If the number above your name is  
or less, it s time to renew!

**77**



**SPECIAL OFFER**

**PRIZE DRAWING!**

see page 5 for details