

# Many Happy Returns

The Official Newsletter of the United States Boomerang Association

## INTERVIEW WITH A MOLEMAN

MoleMan speaks candidly about his boomerang roots, life, and "Gelling".

By Dave Hughes

**DH:** Where, when, at what age, and thru whom did you first get into boomerangs?

**MoleMan:** Well, lets see... My first boomerang I threw was back in 1972. I was 10 years old, living in Las Vegas NV. I was playing right field on a little league team. Sometime during the game, I saw a red boom stuck in a tree off to the right of the field. When the game ended I climbed the tree and got it. It was an old Wham-O. When I got home I went out into the desert (empty lot ) and gave it a throw, right into a big rock and it broke into about 3 pieces. Twelve Years later..... While living in Berkeley Ca., I was 22 years old and about 6 months out of a 4 year stint in the Coast Guard. I saw this guy who rode around on a Moped with boomerangs in the basket. It turned out we both had mutual friends in the punk rock and skateboard crowd. That guy was Mike Girvin (not 'Gel' yet). One day I ran into Mike at an outdoor punk rock show, Mike asked if he could borrow my skateboard for a skate contest at an abandoned miniature golf course, so lent him my board.

(see MoleMan page 6)



Photo: M.Mohr

MoleMan (John Anthony), gives his Ola Wahlberg DeeVee, a toss during the warm-up session for Aussie-Round at the '04 Nationals. The same boomerang used to set the World Record back in 1996.

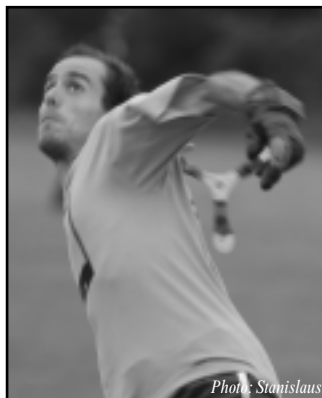

Photo: Stanislaus

Manuel Schütz successfully defends his title as World Champion.

the final event. All teams hoped they'd prepared for the conditions at the WBC and prayed for good luck and no injuries.

The WBC consists of two competitions. The first is a Team Cup, where national teams and multi-national teams compete. The second part of the WBC is the World Individual Championship.

## Europeans Sweep WBC

USA Places 4th in a tightly contested tournament

By Clay Dawson & Steve Kavanaugh

The 2004 World Boomerang Championships (WBC) were held in Charleville-Mezieres, France, July 14-20.

The 2004 WBC competition was truly world class with event scores continuing to improve in every country. Top teams try to take an early lead then hold the momentum and drive through to

### In This Issue:

Presidents Letter ...page 1
Local & Abroad ....page 2
Clubs .....page 3
Sporting News .....page 4
Comp Round-up ...page 8
Plans .....page 14
USBA Info .....page 16

(see WBC page 8)

# THANK YOU KENDALL

For All Your Hard Work On The MHR  
And To The USBA

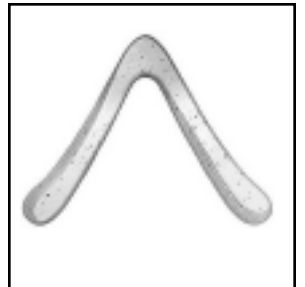

The new editorial staff of the MHR would like to thank Kendall Davis for his tremendous work as the MHR editor. Kendall not only put together each issue by himself for as long as he did, Kendall also contributed to many other USBA functions as well. This page is to say thank you for all your work in promoting the sport of boomerangs through your work in the USBA.

The pictures above are only some of Kendall's boomerang designs along with an action shot from the '04 Nationals. Kendall's entire boomerang collection can be seen and purchased through his web-site at:  
<http://www.master-designs.com/>



# Letter from the President

USBA members,

A new USBA Board's term has started. Thanks to those of you who voted. I'm looking forward to working with the board this next year. I think it has a lot of great ideas and you'll be hearing about them in future MHRs.

A lot has happened since the last MHR. The USA Boomerang Team went to Charleville-Mezieres, France to compete. I feel excitement and focus on building a team to compete in the 2008 World Boomerang Championships in Japan. If this excitement continues to grow and the focus remains tight, the 2006 Team will be the best ever.

There was some internet controversy about the USBA joining the International Federation of Boomerang Associations (IFBA) and then how Brazil's bid for the WBC in 2006 was handled by the IFBA. Everyone involved wishes that this situation had been handled better. I believe the IFBA will be a step towards a more open selection of WBC venues and international rules of competition. The best part of this is that the IFBA laid out what they think the Brazilians needed to do to be a host for the WBC in the future. Good folks like Gregg Snouffer and Betsylew Miale-Gix have worked with the Brazilians to help them meet the IFBA's criteria. One of the steps the IFBA put forward was to host an international competition, so, in the summer of 2005 Brazil will host the first ever Pan-American Boomerang Championships – I'm very excited about this. Now if I can get the time off and the money, you can bet I'll go.

We've had a successful USA Boomerang Expo, hosted by boomerang legend, Chet Snouffer. We've held an election, where a new board was elected and the current USBA logo was retained.

This year the board will be working on keeping Job 0 going and

continue improving our membership services. Also we are going to work on better communications with the membership. The IFBA/Brazil controversy drove home the need for the board to communicate more and better with the membership. Our first step has been to provide a membership ombudsman who will be focused on making sure the USBA\_Info Yahoo group gets frequent updates on board activities. Dave Hughes is YOUR Ombudsman. I encourage all USBA members to join the USBA\_Info Yahoo group, that way you will all get up to date USBA information. Other steps we are making, is an update to the USBA web site, and our continued support of the MHR Editor. We are currently considering some new USBA programs. The "boomerang for every kid" program where the USBA will attempt to provide booms for any kid who asks for one, free of charge. And a new USBA Rated Tour and Tour Championship Finals are both being considered by the board and will be voted upon soon. We are also working to determine how the next US Boomerang Team will be selected and who will be in charge of the sponsorship drive for USBA activities and the US Boomerang Team.

The online forum (USBA\_Info), has been bubbling up some excellent ideas on what the USBA should be doing in the upcoming year or so. The ideas so far are:

- Better Tournament Director Packets we hope to put this on the USBA web site for easy download.
- Member blog area on the web site, we are trying to figure out what this is and how it would work on our web site.
- Focus on promoting more tournaments – Steve Kavanaugh (your new VP) will be heading up USBA Rated Tour and Tour Championship Finals program, we hope this builds excitement for more tournaments.

- Foster local growth without cost to the host – this idea is great. People get excited when they see us throwing boomerangs, they want to try it out. A great way to grow is to hold a weekly throw some place where people will see us throwing and go weekly to learn about Booms.

The board is looking forward to getting even more ideas from our membership and will do our best to implement them or help our membership implement the ideas. Keep those ideas flowing!

Hey, some late breaking news! Kendall Davis has retired from being the MHR editor. Thanks for all you've done, Kendall. YOU RAWK! Kendall has handed the reigns off to Morri Mohr. Who brings some past news letter and publishing experience to the MHR and some new energy and ideas. I'm excited to see the Morri's first MHR! The board has organized itself to support Morri in finding material for the MHR.

See you on the field!  
Clay



Clay shown finishing his leg in the 30 Meter Relay Event.

# Local & International News

Keeping you up to date on all that's happening in the U.S. and around the world  
(to have your tournament listed contact: [mhrstaff@usba.org](mailto:mhrstaff@usba.org))

## 2005 US Tournaments & National Championships

### Tucson Don's Annual May Day Tournament

April 30 and May 1, 2005

Standard Events - Kick off the new year in sunny Arizona for Don's fantastic tournament. Don is also planning a tournament for October (more details to follow)

Hosted by Don Monroe

Call or e-mail for more information

[monroe5@comcast.net](mailto:monroe5@comcast.net)

520.744.6309

### USBA National Championship Tournament & Expo

July 28 to 31, 2005

White River Junction, VT

Hosted by John Flynn

[activermont@cyberportal.net](mailto:activermont@cyberportal.net)

Super 8 White River Jct. VT

802-295-7577

Pool, 30 rooms reserved \$50/night  
(mention US Boomerang Nationals)

Sunset Motor Inn Lebanon, NH

603-298-8721

Close just south of field, quiet: 7-9 rooms available, \$70-\$80/night, other options available, all in \$90-\$120/night range

### 26th Annual Free Throwers Fling

August 5 - 7

Smith Park, Delaware, OH

Hosted by Chet Snouffer

The longest running tournament in the US.

Contact Chet at:

[leadingedgechet@columbus.rr.com](mailto:leadingedgechet@columbus.rr.com)

Look for more 2005 US tournaments to be posted in the next issue of MHR.

## IFBA Update:

On the International Scene, the IFBA continues to organize itself and is gaining more national members. The new website for the IFBA is up and running, it will continue to be updated and improved by Axel Heckner of Germany. It includes an international competition calendar, member countries flags and web-pages, an online forum, etc and can be found at:

<http://www.ifba-online.com>

The National Association members of the IFBA are as follows:

- (AU) Boomerang Association of Australia
- (CH) Swiss Boomerang Federation
- (DE) Deutscher Bumerang Club e.V.
- (ES) Asociacion española de Tiro de Boomerang
- (FR) France Boomerang Association
- (IT) Società Italiana Boomerang Sportivo
- (JP) Japan Boomerang Association
- (NL) Algemene boemerang Organiziet
- (UK) British Boomerang Society
- (US) United States Boomerang Association

Of note, Brazil has formed a national boomerang organization and should be joining the IFBA in the next year. Also, Denmark has plans to join in the near future as well.

## 2005 International Competitions:

**BUMERANG European Championchips -**  
Europameisterschaften COLOGNE - KÖLN  
2./3.7.2005

**European Boomerang Cup**  
[contact@boomerang2005.de](mailto:contact@boomerang2005.de)  
Horst Faika  
[HFaika@t-online.de](mailto:HFaika@t-online.de)

**The First Campeonato Pan-Americano de Bumerangue: (American Boomerang Cup)**  
Dates: August 23-27, 2005  
Sao Paulo, Brazil  
Mark your calendars now!  
Details coming early, 2005

## World Boomerang Championships

The 2006 World Boomerang Championships will be in Asahikawa, Japan hosted by the Japan Boomerang Association and Rangs Japan. It is scheduled for July 2006 and will be located on Hokkaido, one of the far north islands of Japan.

And of course, the 2008 World Boomerang Championships will be hosted by Washington Boomerang Club, in Seattle, WA USA. Dates are set for August 17 to 28, 2008.

For more international dates, check the International Boomerang Calendar, which is hosted by Francois Besoli of France  
<http://ical.mac.com/WebObjects/iCal.woa/wa/default?u=azpro&n=boomerang.ics>

[www.theboomerangman.com](http://www.theboomerangman.com)



"Fast, Personal, Service" since 1975. . . is a fact. . . just ask the next boomerang thrower you see!

Get your free Illustrated Boomerang Catalog (available by mail only). Orders are accepted by phone, fax, email and my convenient order form.

Toll Free: 800-260-8157

# Boomerang Clubs

Contact Information For Boomerang Throwers Around The USA  
Including On-line Groups

If you would like to have your club or on-line group added to this list send your information to:  
[mhrstaff@usba.org](mailto:mhrstaff@usba.org)

## ARIZONA

### Desert Ranglers

Mark Weary & Don Monroe  
4026 East Cholla Canyon Dr.  
Phoenix, AZ 85044  
480.759.3973

## CALIFORNIA

### S.C.O.R.E

*(Southern California Organizations of Rang  
Enthusiasts)*

SCORE has a bi-monthly throwing session  
held on the beach or at a local High School.  
Morri Mohr, John Villagrana & Kris Kemp  
262 27th Street  
Hermosa Beach, CA 90254  
310.493.7100

## COLORADO

### Richard Pollack-Nelson

#### Colorado Boomerangs

2530 S. Ouray Way  
Aurora, CO 80013-1576  
303.368.5933

## CONNECTICUT

### The Wandering Nutmeg Boomerang Society

Paul D. Sprague  
782 Boston Post Rd.  
Madison, CT 06443  
203.245.8211

## FLORIDA

### Flite Stix Boom Slings

Rich Surace  
855 E. Crisafulli Rd.  
Merritt Island, FL  
407.452.3963

## ILLINOIS

### Rock Island

Kendall Davis has a fully stocked  
boomerang shop with several materials to  
choose from and virtually any crafting tool  
you may need (*if you make it, you take it*).  
There is also a guest bedroom for use and  
the greatest cook in the Midwest prepares  
the meals.  
Ph. 317.793.9885 or send e-mail to:  
[boomerang@master-designs.com](mailto:boomerang@master-designs.com)

## INDIANA

### Indianapolis Boomerang Club

Tony Brazelton  
1184 Barrington Dr.  
Greenwood, IN 46143  
317.883.2334  
[brazelami@yahoo.com](mailto:brazelami@yahoo.com)  
[http://www.usba.org/chapters/  
indyboomclub](http://www.usba.org/chapters/indyboomclub)

## NEW MEXICO

### Sandia Boomerang Club

Steve Sanders  
10408 Woodland, NE  
Albuquerque, NM 87111  
505.294.8842  
<http://homepage.mac.com/boomerangs>

## OHIO

### Canton

Gary Broadbent's boom shop and field next  
door. One of the most prestigious shops in the  
country, fully outfitted with materials for mak-  
ing all types of boomerangs. Featuring pro-  
longed boomerang-making sessions followed by  
3:00 am grilled cheese sandwiches, surrounded  
by one of the world's most extensive collections  
of boomerangs. Call Gary at 330.492.RANG  
to inform of your arrival.

## Delaware

Gregg's Boom shop and field down the road.  
Stop in, make and throw some booms and sign  
the guest book.  
Nightly drink specials. Call Greg at  
704.363.4414 or e-mail at  
[boomerang@columbus.rr.com](mailto:boomerang@columbus.rr.com)

## TEXAS

### Republic of Texas Boomerang Society

(TexBoom Yahoo! Group)  
Dave Hughes  
1818 Cotton Mill Ct.  
Richmond, TX 77469  
281.341.0934  
[dlhughes001@juno.com](mailto:dlhughes001@juno.com)

## PENNSYLVANIA

### Allentown

Dave Hendricks  
"P/NJ Boomerang Group"  
1086 E. Gordon Street  
Allentown, PA 18103-2208  
610.434.7305

## VERMONT

### Vermont Boomerang Association

Paul Gustafson  
South Burlington, VT  
802.859.3430  
[paul@vermontboomerang.org](mailto:paul@vermontboomerang.org)  
<http://www.vermontboomerang.org>

## VIRGINIA

Steve Cook  
757.926.4823

## WASHINGTON

### Washington Boomerang Club

Steve Kavanaugh  
206.784.0453  
Billy Brazelton  
206.547.1449  
[throwbooms@waboomclub.org](mailto:throwbooms@waboomclub.org)  
<http://www.waboomclub.org>

## ON-LINE GROUPS

### Boomerang Talk

Your one-stop, non-stop online boomerang  
club. Stay up to date on the latest info and  
chatter from the boomerang community. You  
can join at:  
[http://groups.yahoo.com/group/BoomerangTal  
k/join](http://groups.yahoo.com/group/BoomerangTalk/join)

### BoomerangComp

This new group is for the promotion, advance-  
ment and coordination of boomerang competi-  
tion including on-line tournaments.  
You can join at:  
[http://sports.groups.yahoo.com/group/Boomer  
angComp/](http://sports.groups.yahoo.com/group/BoomerangComp/)

### LDBoomerangs

This group is for all those interested in Long  
Distance Boomerangs. Information on making  
LD's, materials, plans, techniques, throwing,  
and upcoming LD competitions is all in here!  
You can join at:  
[http://sports.groups.yahoo.com/group/LDBoo  
merangs/](http://sports.groups.yahoo.com/group/LDBoomerangs/)

### TexBoom

A place to share information and ideas, or just  
to talk about our favorite subject...  
Boomerangs! Also, a vehicle for announcing  
upcoming boomerang events and news about  
what's going on in the Texas boomerang scene.  
You can join at:  
[http://sports.groups.yahoo.com/group/TexBoo  
m/](http://sports.groups.yahoo.com/group/TexBoom/)

### USBA\_info

This is a USBA members only group for the  
online discussion of issues. The group is closely  
monitored by the Board which makes for an  
"open door" policy for complaints, props or  
concerns. You can join at:  
[http://groups.yahoo.com/group/USBA\\_info/jo  
in](http://groups.yahoo.com/group/USBA_info/join)

# The Sporting News

Featuring Individuals and Events Related to Sport Boomerang Throwing and Crafting

Featured Thrower and Boomsmith:

## Steven Graham of Oklahoma

As told by,  
Steven Graham

I became obsessed with boomerangs when I found the Darnell and Ruhe book at a science museum (*Boomerang, by Ben Ruhe & Eric Darnell, Workman Pub., Co., 1985*). I made my first boomerang about 15 years ago with plans from the book. I was an art education major at Oklahoma State University at that time. I now teach art at Kane Elementary School in Bartlesville Oklahoma. I teach kindergarten through fifth grade. My fourth and fifth graders all make paint paddle boomerangs and all classes make indoor laminated tag board boomerangs. Students also compete with boomerangs in a modified accuracy game.

I sell my boomerangs under the name Graham's Boomerangs. I mostly sell boomerangs that are personalized with calligraphy and art work. Most customers buy them to give as gifts. I also like to make lap joint boomerangs from beautiful hardwoods (the ones I am not allergic to). I like to sell my best boomerangs in Ted Bailey's boomerang auction.

Some of the other things I become obsessed with are didgeridoo making and playing, making medieval armor, renaissance clothing, miniature castles, knife and ax throwing, Star Wars and Star Trek, painting and drawing, digital art, Halloween masks and costumes, magic, kites, but I always come back around to boomerangs



*Steven Graham making a nice catch with one of his Fuzzies.*

I have a wife Cindy, and two boys Trevor 10, and Dillon 8. We have two dogs, and two pet birds.

I am Vice-President of the Bartlesville Art Association and am

heavily involved in that organization. I display and exhibit boomerangs in art shows whenever possible.



*You've got to have a real passion for crafting boomerangs to have a shop this broken-in.*

# here & there

SNAPSHOTS FROM AROUND THE  
**BOOMERANG**  
WORLD

**A RANDOM LOOK AT A FEW BOOMSHOPS AND THROWERS FROM AROUND THE US AND BEYOND**



*John Gaston's boomshop, I think I see a boomerang somewhere in there?*



*Now this is a boomshop, unfortunately I lost the name of the owner*



*Dave Hendricks milling the day away*



*Pierre Kutek's bathroom/paintroom*



*The B-Man's other passion... music*



*Don Monroe and his boomshop, rumor has it Don's about to unveil something really big*



*Tom Conally submitted the "Serpent" and the B-man submitted the "Guiding Star", interesting combination*



*S.C.O.R.E. Boomerang Club in full dress (see clubs page)*

# MoleMan...

(continued from page front page)

Mike's rounds were the raddest to watch with the tricks he would "attempt." They were of the most difficult levels. Fortunately, he didn't complete any of the tricks, but his great exciting attitude grabbed everyone's attention. A local punk rock kid who went by the name of Johnny Puke heard someone yell "Mike, you're Gelling!", to which Johnny yelled "Team Gel!" That was the day Mike and I became friends.

A week or so later I saw Mike at the park throwing. I asked if he would show me how to throw. I think my first throw was with a green mini hook, a Peter Ruhf, maybe. It did about 30 meters and came right back to me. I was hooked. For my soon to come birthday, Mike gave me 6 boomerang blanks and showed me how to make them. A few weeks later Mike hosted a tourney at Billy Martin Field. I went to enter the novice division, but there were only 2 of us, so they mixed us in with the others. I took 3rd overall! I was more hooked. A few weeks later, we flew down to LA for the 1985 North Ridge Boomerang Nationals. The second day, we were running late, and when we got to the field everyone was already lined up for Suicide Trick Catch. I only had on one shoe and no time to put on the other. So I did the event with one bare foot. Place-wise, I was in the basement, but fun-wise, I was on the roof. We met great throwers and boomerang people like Ben Ruhe, Barnaby Ruhe, Peter and Larry Ruhf, Dennis Joyce, Ali Fujino Miller, Chet Snouffer, etc. There are just too many to name. We both had a blast. I was very hooked.

I moved to Connecticut that fall. The following Spring I went to see a Boomerang Demo at the Peabody Museum, New Haven, and saw a lot of the people I saw at the Nationals the summer before. They told me about Dennis Joyce's tournament the next week in Virginia and I drove down to throw. I've been totally hooked since.

**DH:** This question will certainly come up sooner or later, so I'll just get it out of the way now...How did you get the nickname "MoleMan"?

**MoleMan:** How did I get the name MoleMan.....I've always wished this was a cooler story but here it is.....In 1982 I had been on the 378 foot High Endurance Coast Guard Cutter Rush for about 2 years. I was a 3rd class Petty Officer Damage Controlman. I had just started hanging out in the punk rock crowd in which several guys had shaved heads. I thought I'd do the same with mine. My very good friend and fellow shipmate Enzo T. Maniac, was shaving my head and several small moles were uncovered on my scalp. He made a remark about the moles and I began to show him I had several hundred all over my body.



(372 when I was about 12 years old. I counted them.) Then he said "We should call you Mole Man." He pushed it around the ship and the crowd we hung around, and it just stuck. Mike Gel, knowing me as MoleMan when we started to hang out, helped push it around the boomerang scene.

**DH:** So, you've been involved in the sport since very early in its existence. Did you ever think it would grow to an international sport, with the WBC and all? What are your thoughts on the state of the sport nowadays?

**MoleMan:** I always knew it would grow. Just the way people are amazed when they see their first boomerang

in flight let me know it would grow more. I actually always thought it would grow faster than it has. The idea of getting into the Olympics as an exhibition sport has bounced around for years. I always imagined we'd be there by now.

I was a member of the 3rd U.S. team in the first Team Cup in 1987. Being able to meet all the other throwers from around the world opened my eyes to how big it already was. People have been doing photo shoots, press conferences, demos, TV shows for many years now. More sponsors could really help us along. I was part of the winning U.S. Team Blue at the 1992 Team cup in Hamburg. We had a company sponsor us who was selling the Tri-Fly boomerang. They helped with the travel expenses, gave us uniforms and bags, and put our picture on the back of the package. They told us it did them no good to have a picture of the #2 team so we had to win. So we did.

After that Eric Darnell, Rob Parkins, and I were sent to do demos at beach clubs on Long Island and Cape Cod. They also sent us to spring break for a week. My point is that there are companies out there that can help the sport grow much bigger. I have to say though, that I like the fact that the sport continues to advance in aerodynamics and design.

It has never become stale or outdated. It's great to see the scores of all the different events continue to grow. It's also great to see the kids of throwers out competing. I remember watching Adam Ruhf compete at 10 years old. Then watching him grow into the fantastic thrower he has become. Seeing Bart and George Flynn grow and become the next to step up and continue in Dad's footsteps. And seeing Cody Snouffer, and Logan Broadbent as young men now matching and beating Veteran throwers thrills the @#\$\$%# out of me. I have three that just started last year. Another 5 years and



you'd all better watch out! I would like to see more regional tournaments again, and other formats to shorten competitions for a more spectator-friendly sport. I think the sport is still moving along strong but could grow stronger.

**DH:** What are your favorite competition events, and which are you best at? I've found that those two answers are not always the same.

**MoleMan:** Of course, my favorite is GLORP! Also Hackuracy, and Style Outback. My favorite USBA event is a tough question. I love the mellowness and beauty of MTA, the extremeness of Fast Catch, and the flow of a great Endurance round. Even though I have the Aussie Round World record, it's not my most consistent event; that would be Endurance. Nothing feels better to me than a fast and smooth endurance round. You just kinda get into a zone. Throw, turn, catch. Throw, turn, catch. Same with a quick Fast Catch round. When you know you're 'on' in Aussie Round, you can still get that 'flow' feeling. I'm not purposely leaving out Trick catch and Accuracy. They're also fun and difficult events. I used to really like Juggling a lot. I kinda miss it. I am happy to see Distance making a come back. (no pun intended)

**DH:** Do you make booms at all? If so, please describe them for us; what types you make, etc.

**MoleMan:** I make a few a year for my kids, but not as much as I used to. I used to like to make peoples initials for their birthdays. I once made one that was three different shaped boomerangs all attached at the elbow to a disk with a big hole in it. It was very cool. Flew great, lots a hover time. But my dog chewed a big chunk off one wing. I've made a lot of PVC foam three bladers. I call them Easy Flyers. They do about 10 meters. My first boomerangs had hand painted faces on them. I heard there are a few in some collections out there.

**DH:** If you don't mind telling us...what's in your competition kit? Which are your favorite booms for each event?

**MoleMan:** Once you dig through the old tape, harmonicas, broken booms, and Kipperred Snacks and Chips, the lunch of champions, you'll find a variety of booms.

For Accuracy, I've been using a Tri-Fly I've customized with holes, coins, and flaps. I've used it for about 6 years. For Aussie Round, I've used the same boomerang for nine years since I set the World Record. It's an Ola Wahlberg. I also like the old Volker Behrens Wind Eaters. For Trick Catch, I use a Tri-Fly that I've also customized myself with fewer holes. For Doubling, I use a pair of Gel Booms. My insider has a wing missing the tip. Never worked better. MTA, I used a Jonas until I lost it. Now I use a Manuel Schütz, until I lose it. Then I'll try a Bonus. For Fast Catch and Endurance, I have several Eric Darnell customized Tri-Fly's. I've used Eric's Fast Booms for over 12 years now. I had a 17.49 sec. Fast Catch in Hamburg in 1992 with an Eric boom. Then I broke it. I also usually have a Volker Carbon Challenger II and a Bull Roarer.

**DH:** Do you practice a lot for competition? Are there any special preparations you make to get ready to compete?

**MoleMan:** I'm the type to try to get out 2 or 3 times the week before a comp., but usually get maybe an 1/2 hour. The very first thing I do is shave my head. Sometimes leave a boomerang of hair on one side. Then I get out my black Fedora. Next, I pick out a cool boomerang shirt from a past comp. I make sure I pack my reclining chair, field umbrella, and shade umbrella. On the way to the field, I pick up the Kipperred Snacks, Gatorade, and water. After I get everything set up, I put out my travel Buddha and altar, with offerings of fruit, incense, and water. Then I prepare for a great day of fun.

**DH:** How about some biographical information about yourself? Where do you live, what's your occupation, marital status, pets, fave foods, other hobbies, etc.?

**MoleMan:** I was born in Barstow, CA at Fort Irwin Army Camp. At three years old we moved to

Las Vegas, NV. I went all through school there and left when I joined the Coast Guard. From there I stayed in Berkeley, CA and met Mike Gel.

I now live in Great Barrington MA. in the Berkshire Mts. I've been a carpenter by trade for twenty years and currently work building redwood wine cellars.

I'm divorced with three kids Kyle 12, Zach 10, and Zoe 10, who also have competed for the last 2 years. I have a Pit Bull named Chickie Babe, and a loud Beagle named Chester. I'm a big meat and pasta eater, but I've recently started eating lots of fruit. I play a lot of softball, and bowl a lot. In the winter I snowboard as much as possible, about twice a week. Three nice ski areas in the area. I also like volleyball, darts, hiking, bike riding and fishing. Most of all, doing it with my kids.

**DH:** What's been the coolest thing for you about your involvement in the hobby & sport of boomerangs; what's it done for you, and vice-versa?

**MoleMan:** I'd have to say the people I've met and the great friends I've made is the coolest thing. I now have friends around the world. The travel has been great. Europe twice, Australia, New Zealand, Canada, and all over the US The press has been fun too! I've had much more than my fifteen minutes of fame. My favorite is last year Barnaby Ruhe, did a shoot for Ripleys Believe it or not.

(see MoleMan page 13)



# Competition Round-up

Comprehensive Coverage of Tournaments, Upcoming Events and Techniques Related to Competition

## B-MOTIONS TAKE TEAM GOLD AT WBC

### Injuries take their toll on US team as B-Motions pulls away.

By Steve Kavanaugh

It was obvious from the beginning that the German Team, B-Motions, was in top form edging out the USA Gel's Angels to win the first team event, Accuracy 100. After mounting a comeback with the Angels winning the 2nd event, Trick Catch, the USA Teams (Gel's Angels and Sonic Boom) suffered from injuries and repeated mistakes starting in the 3rd event, Super Catch.

With the continuing problems on both USA Teams, and the awe-inspiring dominance of the B-Motion, the real race seemed to be for 2nd and 3rd place.

Despite all the problems, Gel's Angels were actually positioned to recover 2nd or 3rd overall in the final event, 30-meter Relay.

But the bleeding never stopped, and with multiple drops in 30-meter Relay, the USA Team disaster was finished. In the end, local European teams swept the podium with 1st place going to Germany's B-Motion, 2nd going to the hometown favorite French Limite a Bloc, and 3rd to Swiss Scandal. The USA Team had its worst showing ever at the WBC with the Gel's Angels in 4th and Sonic Boom in 8th place.



Photo: Stanislaus

Mark Weary "Shark" was the second highest US finisher who placed 9th overall in the individual competition.



Photo: Stanislaus

B-MOTIONS, on the podium celebrating their first place victory (from left to right) Gerrit Goerrissen (coach), Fridolin Frost, Oli Thienhaus, Alex Opri (captain), Gerrit Lemkau, Tom Szartowicz, and Guenter Moeller.

### WBC...

(continued from page 1)

The team competition took place over three days. Team competition includes some individual events where the scores are combined to form a team score. True team events included:

- Super Catch - a combination of MTA Unlimited and Fast Catch
- 20-meter Endurance Relay - fast catch relay of four people each throwing for one minute plus a clean-up round
- 30-meter Relay - each thrower runs to bulls-eye, throws 30-meter boomerang and must catch it before running back to tag next teammate

The individual competition took place over two days and formatted as a standard tournament with Aussie Round, Trick Catch, Accuracy100, MTA 100, Fast Catch, and Endurance.

### WBC Individual Competition

The individual competition was held the next two days. Again the B-Motion showed dominance,

but not quite enough to topple Manuel Schütz for his third consecutive World Individual Championship win. The top three individual finishers were, Manuel Schütz, first, Alex Opri, second, and Fridolin Frost, third. Matt Golenor was the top finishing US thrower coming in 6th with Mark Weary in 9th place.

(continued on next page)



Photo: Stanislaus

Matt Golenor, top US finisher placing 6th overall in the individual competition.

# OTHER HIGHLIGHTS FROM THE WBC...

(more photos and information on the following page)

## James Stickney wins the World GLORP Championship

Between the team and individual competitions was GEL DAY. Mixed nationality teams self organize to play fun games together and just have fun. The only "serious" part of GEL DAY is having fun and then there is the World GLORP Championships. James Stickney, a young and RAD USA thrower and a member of the USA coaching staff and the Hole-in-the-Head Gang, relentlessly dominated the field finishing on top and joining the elite group of throwers who possess the coveted World GLORP Champion red jersey.

## New World Record in TC

During the individual tournament at the WBC, Alex Opri broke the world record in Trick Catch, shattering the old mark of 279 held by Steve Kavanaugh with an impressive 372. Alex's record was then broken later in 2004 by World Individual Champion Manuel Schütz with a new world record of 390. (Manu adds this to his Long Distance World Record, and word on the street is that he is gunning for Adam Ruhf's fast-catch record having broken 14 seconds in practice.)

## 2006 World Boomerang Cup

The next World Boomerang Cup will be held in Asahikawa, Japan, in July 2006. A plan to win back the Cup is currently being developed. It will include three team skill-building camps this summer with a team trials taking place in September 2005. Details will be forthcoming in the Spring 2005 issue of Many Happy Returns

## The USA Boomerang Team

Thanks deeply, the Corporation for International Business, KAVU, Ted Bailey, and Eric Darnell for their generous support.



James Stickney, successfully doing a under-the-leg-eagle catch, known as "The Billy", to win the world GLORP title.

## Team Finish Rank

- 1 B-Motions (Germany 1)
- 2 Limite a Bloc (France 1)
- 3 SKANDAL (Swiss 1)
- 4 Gel's Angels (USA 1)
- 5 Samurai (Japan)
- 6 Funtasticks (Germany 2)
- 7 France 2
- 8 Sonic Boom (USA 2)
- 9 BBS (United Kingdom)
- 10 Braracourcix (France 3)
- 11 Australia
- 12 Swiss Shadow (Swiss 2)
- 13 Les Pas Pareil (Veterans)
- 14 Not from this Planet (Netherland)
- 15 Canada
- 16 Skandinavian Vikings (Skandinavia)
- 17 Sisters-in-Boom (International Women)

## Top 10 Individual Finisher's

- 1 Manuel Schütz (Switzerland)
- 2 Alexander Opri (Germany)
- 3 Fridolin Frost (Germany)
- 4 Oliver Thienhaus (Germany)
- 5 Maiya Junji (Japan)
- 6 Matt Golenor (USA)
- 7 Sascha Winkler (Germany)
- 8 Jérôme Royo (France)
- 9 Mark Weary (USA)
- 10 Thomas Stehrenberger (Germany)



Manuel Schütz making his foot-catch

# MORE PHOTOS FROM THE WBC...



Photo: Stanislaus

The US team members (left to right): Clay Dawson, James Stickney (coaching staff), Jason Smucker, Steve "Cookie" Cook, Mark Weary, Don Monroe, Betsylew Miale-Gix, Richard Bower, Aimee Golenor (coaching staff), Matt Golenor, Tony Brazelton, Will Gix, Daniel Bower, Steve "Stevie K" Kavanuagh, Billy Brazelton



Photo: Stanislaus

Daniel Bower, Billy Brazelton, Matt Golenor and Stevie K, getting ready for the next event



Photo: Stanislaus

Billy Brazelton ready to let loose



Photo: Stanislaus

Richard Bower using a bit of tongue



Photo: Stanislaus

Stevie K making the catch in Aussie Round



Photo: Stanislaus

Will showing some hustle

Edited and Illustrated by Morri Mohr

### *A side by side comparison of the Fast Catch Transition as outline by John Flynn and Adam Ruhf*

#### **John Flynn**

The catch-throw transition is a key element in the Fast Catch event, often making the difference between winning and losing on any given day, and an important component in Team events such as Super Catch and Endurance Relay.

A world-class transition can take less than one second but, typically, in competition under ideal conditions, the transition may take 1.25 seconds. If even 0.1 sec. can be saved on each transition, it lowers the overall time by 0.5 sec. In a tightly contested FC event, the difference between 22.30 and 21.80 can mean 3-4 places in the standings. It is something to consider.

If conditions are windy or otherwise variable, the transition becomes less important than an accurate throw, so the extra time (hopefully not much!) needed to make the precise throw is sound strategy. However, the subject here is the transition, so here is my general approach during a typical FC flight in low wind:

The first half of the flight generally indicates where the boomerang will return. Move into catching position, facing the incoming boomerang with the right foot slightly forward compared to the left, and the body turned slightly to the left. Note: left-handers will do the opposite.

Extend arms out halfway before the boomerang comes in, then pull arms back in with the rang while catching, with the left hand underneath and right hand covering on top. As soon as the boomerang is in control, or even slightly before for the experienced thrower, step away with the left foot towards the direction of the next throw. Correct body position prior to the catch,

#### **Adam Ruhf**

I intentionally throw slightly into the wind when I'm trying to go fast. This is not advisable in any circumstance except this. With any shifting wind, or any necessity of safety, the idea is to stay a little right.

But for second round speed or for low wind showing off - a little into the wind, to the left of where it feels like its coming right home. Just a few degrees into it so that the boomerang comes back a little to your left (outside of you). This is part of the setup. Also for finding the groove in endurance, this helps enormously.

After I release I am immediately moving. Knowing your boomerang well is imperative. Upon release you should know exactly where it's going. I want to place myself on the inside of the boomerang's arc, to the front and left of the circle. The goal is to intercept the boomerang as early as possible. Move towards it, within the limits of the circle, getting yourself on the inside of the boomerangs arc.

As it's approaching I set my feet. Right foot out in front, to the edge of the circle, left foot a little wider than the shoulders (in an athletic stance, almost parallel to the flight of the boomerang). My torso would be set-up so the boomerang would pass in front of my body right to left.

The right foot is very important. It is the foot and leg that

generates the throw. You push off from the right foot. When I catch the boomerang, most of my weight is on my right foot. I am leaning forward into the oncoming boomerang. Catching it is with my arms out all the way. Extended arms. Again, getting it as early in the flight as possible and slightly left of the center of my body.

*(continued on the following page)*

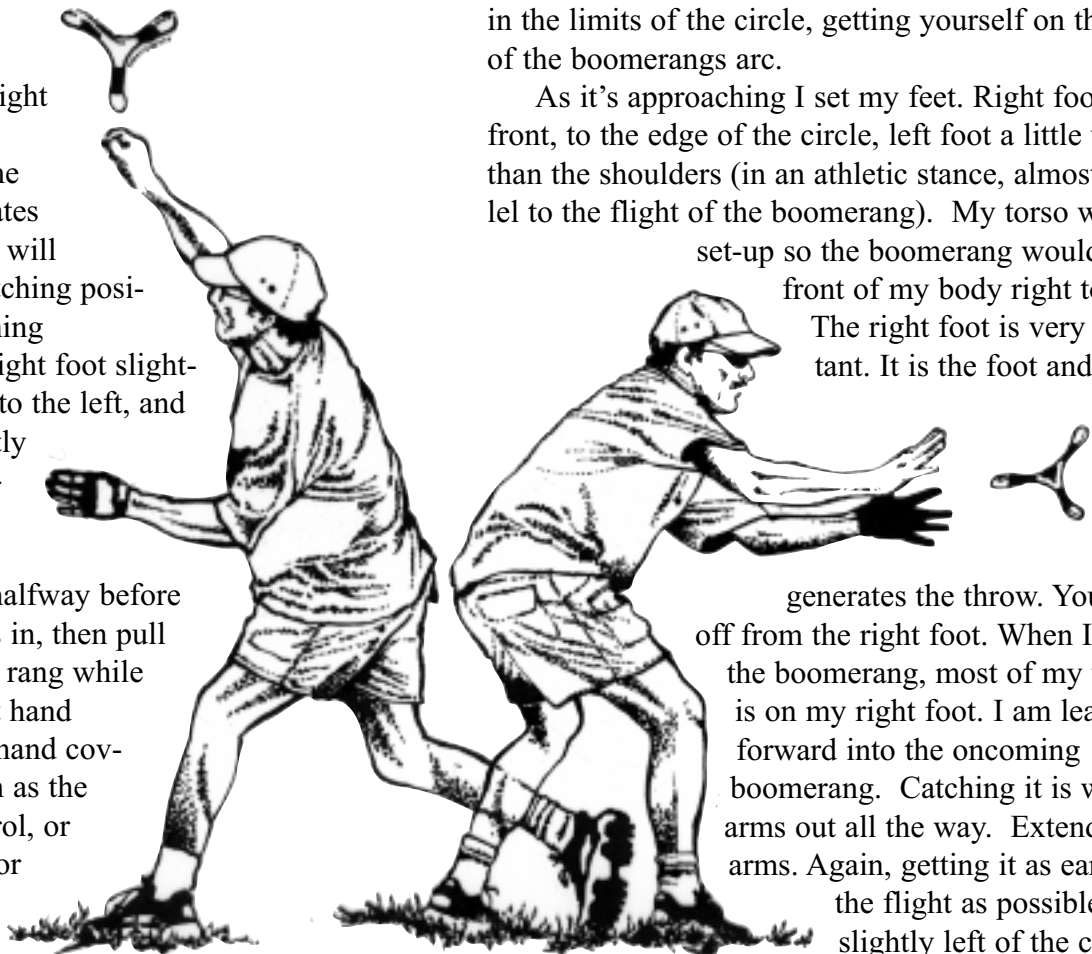

## John Flynn

turned slightly to the left, facilitates a smooth stepping motion, and commits the thrower to the next throw without the need for another step.

While stepping away and into the next throw, the thrower is quickly finding the grip on the boomerang wing with the right hand. The body is moving forward, starting the throwing motion, yet the arms and hands stay back, gripping the boom, thus creating the foundation for leverage needed for a strong release once the left arm comes forward and torso begins to rotate. There is no substitute for practice here, and adopting a sense of urgency, as there is only one chance to make the fast transition smoothly. Fumbling for the grip once the commitment has been made usually results in 1) double-pumping, where the thrower has to stop the throwing motion, secure the grip, and step into the throw again – maybe costing an extra second, or 2) rushing the throw with a marginal grip, which can result in any number of blunders that are usually far more devastating to the round.

Practice the FC transition under calm conditions. A very fast boomerang is not recommended for transition practice, just a steady catchable boomerang where many transition reps can be done. Push the limits and make mistakes in practice by trying to go "too fast" in the transition. If a faster boomerang will be used in the event, work it into the practice session as well. Later on, do some reps with a very fast boomerang if possible, as it makes the fast "event" boomerang seem easier to handle on contest day.

Good luck and see you on the field!  
John

## Adam Ruhf

As I catch, the weight being mostly on my front right foot, I immediately feel the boomerang in my hands. I slide my right hand down a wing as I bring the boomerang into my body. The left hand helps rotate the boomerang to find the wing easier. While this is happening I begin to shift my weight from the right foot to the left foot. From the point I catch to the point I begin the arm motion for the next throw is almost a full circle with my hands.

Catching out and high (or low), bringing my hands back into my body and then out and up again to make the throw. With that circle in mind (which for me is a very real thing), but is mostly for rhythm, I hope to have a full, real grip, ready for the next throw, halfway through this circle, which is the point closest to the body.

While feeling and finding the grip I am pulling my hands back into me. While extending the arm back out to throw, the weight is shifting and the torso begins to twist into a throw. Your next throw begins halfway through the motion of catching. As I extend my arm out I also bend my knee a little and begin to push with the right foot.

Pushing with the right leg. Twisting and driving with the hips. Vertical release, head height, lots of spin. The turnaround should be one motion. There should be an economy of motion. Whatever can be set up and prepared in advance, should. As soon of you have control of the boomerang you should be throwing.

Stay Rad,  
Adam

*Figures 1 thru 5 illustrate the "Circle" as described by Adam. If you follow the path of the boomerang you will notice that from the point of contact (fig. 1), to the where the boomerang starts moving forward to throw (fig.5), it will have made a circle or oval pattern. The smaller your circle the faster your "Transition". In the ideal circumstance to throw from the exact point you catch would result in the absolute fastest Transition but you would probably have hands like bricks and drop many booms. The Circle will give you "soft-hands" and you will develop a rhythm to carry you through a round of Fast Catch or Endurance with Transitions under one second.*

Fig.1  
Contact with boomerang

Fig.2  
Catching and controlling the boomerang

Fig. 3  
Re-gripping the boomerang

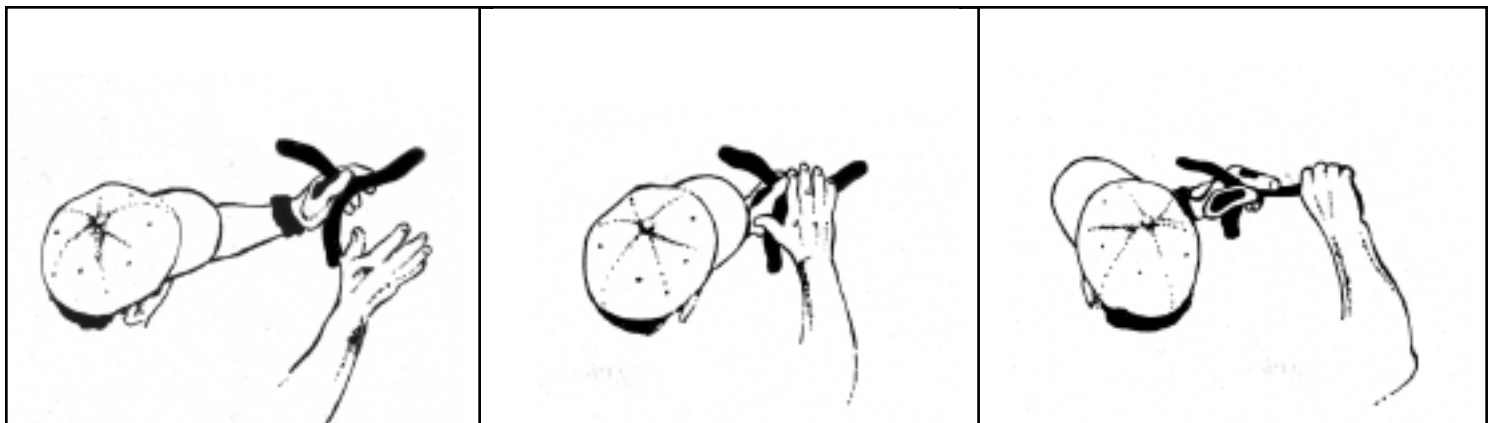



Large Selection of Flying Toys  
including Boomerangs, Throwsticks,  
Aboriginal Artifacts, Flying Rings,  
Slings, Bolas, Atlatls & More.



More than 50 boomerangs to choose:  
Low Cost, Sporting, Art, Collectable,  
Long Distance, Fast Catch, MTA,  
Doubling, Australian Round + more

Boomerang Auction 2X/Year  
<http://www.flight-toys.com/boomerang/auction.htm>  
Next Auction: March - May 2005

<http://www.flight-toys.com>  
[tbailey@ic.net](mailto:tbailey@ic.net)  
(734) 971-2970

# MoleMan...

(continued from page 7)

In the middle of the show it says "...some of the best throwers in the world.", then pans to my face in a group photo.

A colorful life is what I've gotten from boomerangs. Lots of memories, lots of stories, lots of friends. Someone once asked me if I was happy with my life. I told them, "with the amount of things I've done through boomerangs, I'm more than happy with how my life has gone."

**DH:** And finally; what, in your opinion, can "Average Joe USBA Member", whether competitor, collector, boom maker, or casual boomerang enthusiast, do to help the USBA accomplish its goals and to keep it a strong and viable organization?

**MoleMan:** First off, support the USBA and any other regional clubs you can find.

Tell and teach others. When I see people watching, I always offer to teach them how to throw. Many times I've had people stop and ask me if they can try to throw. You may have to teach a hundred or two before you find another enthusiast.

Encourage all people who show up at the start of a tournament to enter. Even if it's their first time. Sometimes they just need a nudge.

**-End**

Fig. 4  
Extending for throw

Fig. 5  
Throwing the boomerang

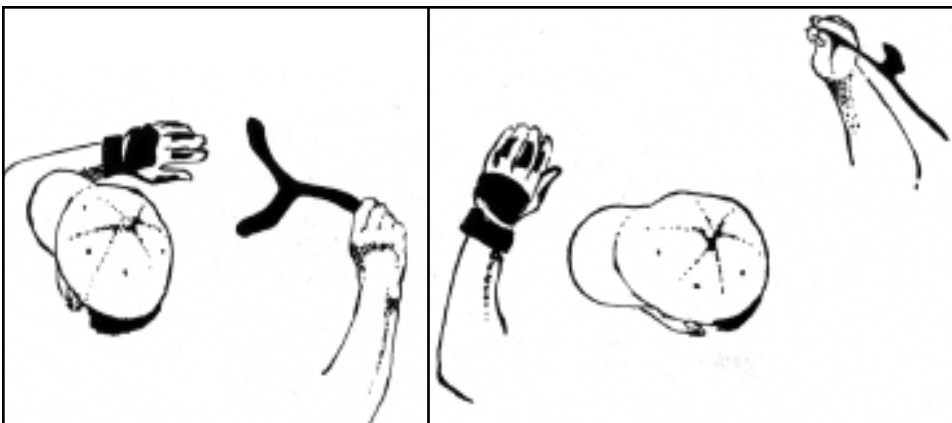

**Chet Snouffer**  
**SE-3**  
**Fast Catch**

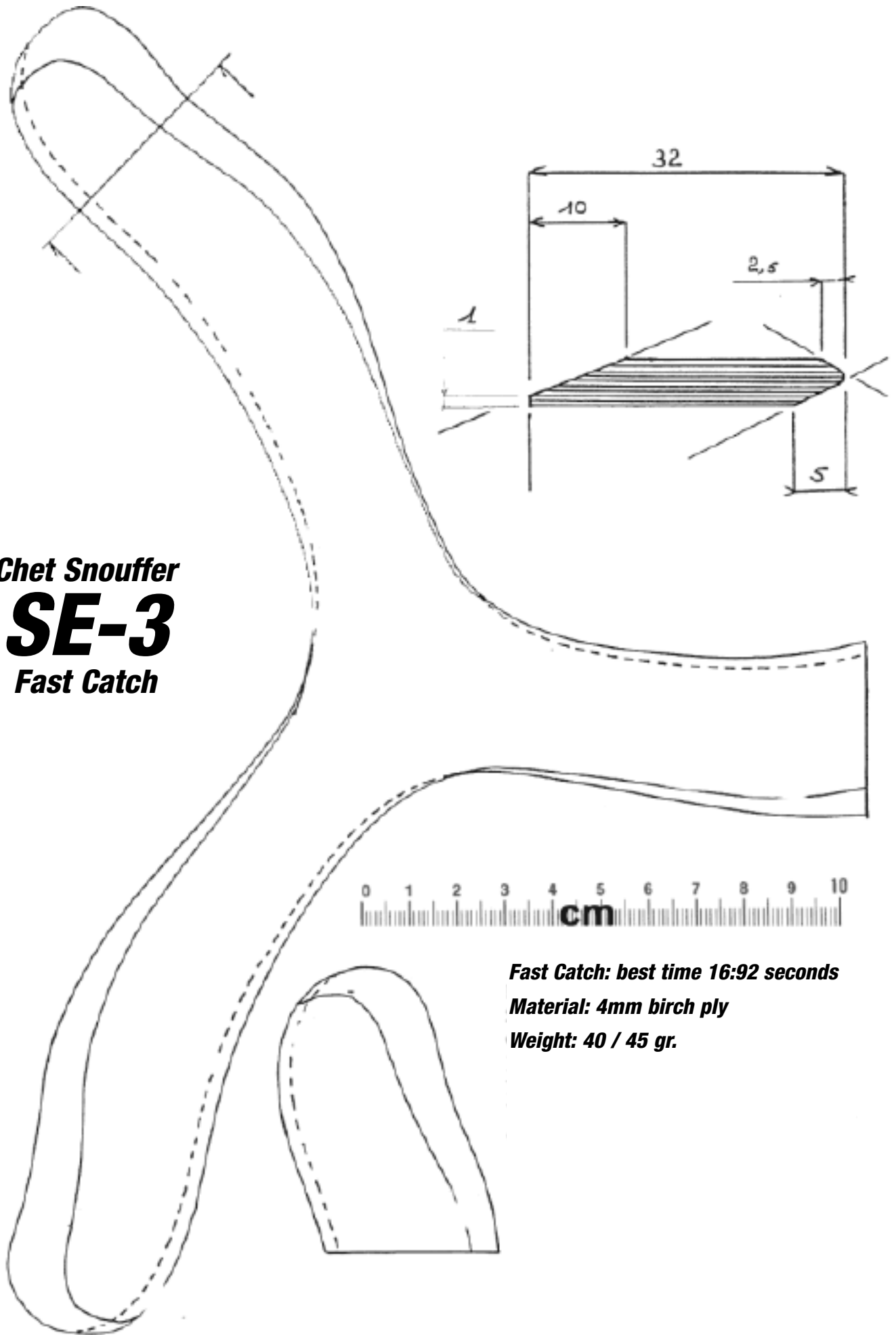

**Fast Catch: best time 16:92 seconds**  
**Material: 4mm birch ply**  
**Weight: 40 / 45 gr.**



Michael "Gel" Girvin  
Gel Sunshine  
3mm Linen phenolic  
Aussie Round

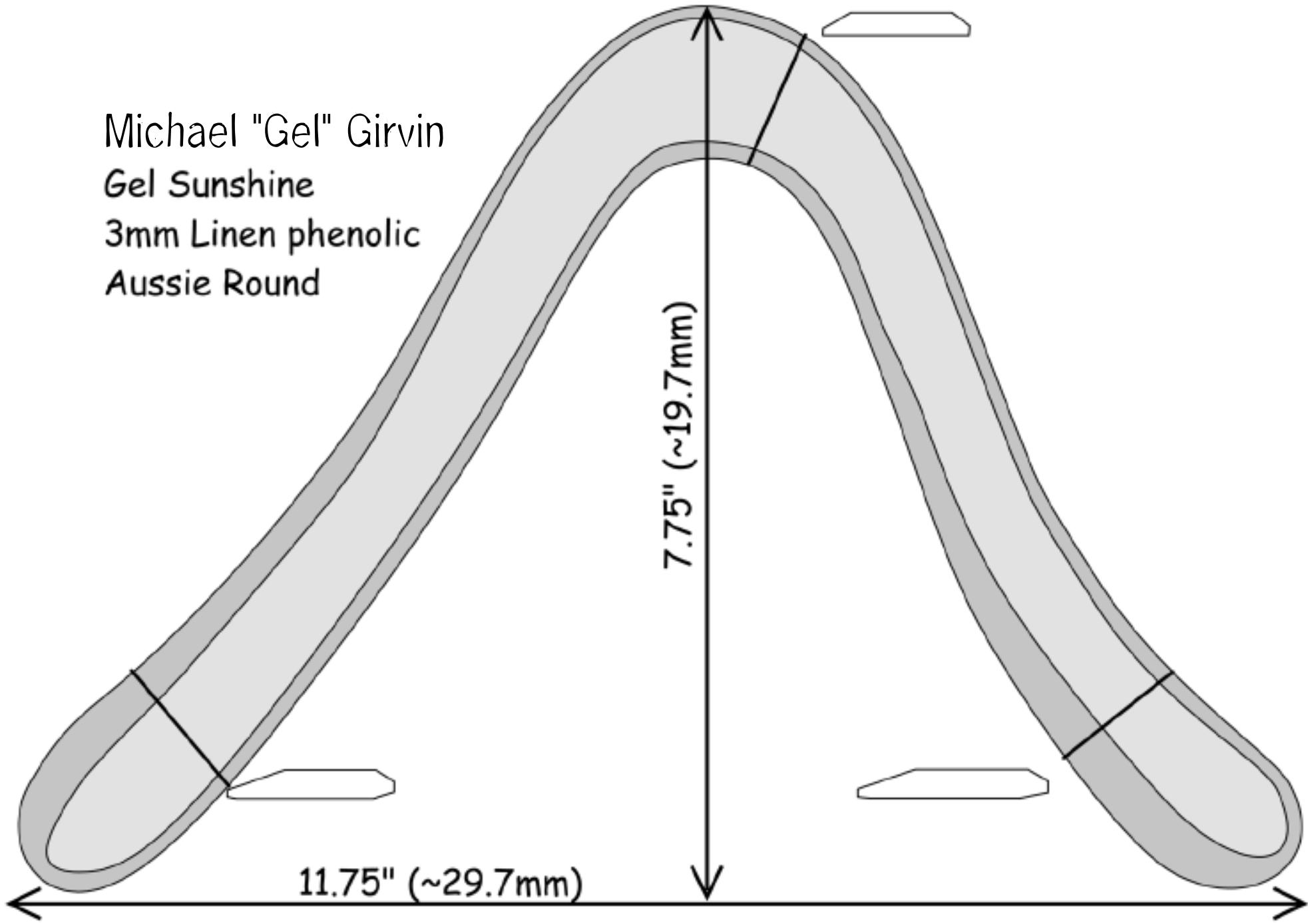

11.75" (~29.7mm)

7.75" (~19.7mm)

## USBA Membership Information

USBA Membership benefits:

- MHR Newsletter subscription
- Access to the USBA info web group for USBA related discussions.
- Discounts at Anderson International Trading Co.
- Participation in all USBA tournaments and events

E-membership receives PDF of MHR via email. Family memberships are good for up to three household members.

### Membership Application

Check:  New  Renewal

Membership Type (check):

- Individual (e-membership) \$15
- Individual (print) \$20
- Family \$35
- International (print) \$25

Name \_\_\_\_\_

Address \_\_\_\_\_

City, State, Zip \_\_\_\_\_

Phone (optional) \_\_\_\_\_

email (optional) \_\_\_\_\_

Send completed form to:

USBA Membership  
3551 236th Street SW  
Brier, WA 98036-8421

## Many Happy Returns

Circulation: 400 Worldwide  
Published by the:

United States Boomerang  
Association

3551 236th Street SW  
Brier, WA 98036-8421

### Editor/Art Director:

Morri Mohr  
Mohr41@yahoo.com

### Publishing Director:

Clay Dawson  
clayton.dawson@  
honeywell.com

### Copy Editor/ Advertising Director:

Suzanne Ragan Lentz  
suzanneraganlentz@  
earthlink.net

### Mechanical Measurements:

Image area: 9.5" by 7.5"  
Three columns to a page  
Width of column: 2.25"

### Advertising Rates:

Full Page-inside front or back cover	\$125
Full Page or Half Page-back cover	\$100
Half Page	\$75
One Column	\$50
Half Column	\$30

All advertisements must be pre-paid by check, money order, or PayPal to the USBA. Publisher reserves the right to refuse any advertisement or cancel a contract without reason.

Email advertisements  
in TIFF format to:  
Suzanne Ragan Lentz  
suzanneraganlentz@earthlink.net

Deadlines for advertising are:  
March 1 for the Spring issue;  
June 1 for the Summer issue;  
September 1 for the Fall issue;  
December 1 for the Winter issue.

## USBA INFORMATION

The USBA is a non-profit  
volunteer organization.  
Our mission is to promote the  
sport, craft, history and  
science of boomerangs in  
the United States.

Your input is always welcome.  
You can contact the USBA  
through a member of  
the board of directors  
(listed below) or by joining  
our Yahoo Group USBA\_info.

## USBA Board of Directors

### President

Clay Dawson  
clayton.dawson@  
honeywell.com  
(425) 643-6298

### Vice President

Steve Kavanaugh  
teangel@aol.com  
(206) 784-0453

### Treasurer

Betsylew Miale-Gix  
betwil@att.net  
(425) 485-1672

### Secretary

Andy Cross  
Across@telusplanet.net  
(403) 293-7307

### Directors

Billy Brazelton  
braz@u.washington.edu  
Dave Hughes  
David.Hughes@bakerhughes.com

Stu Jones  
Circlestixstuk@webtv.net

Delaney Mohr  
delaneymohr@yahoo.com

Mark Weary  
mark.weary@cox.net



# ...parting shot

Please send any suggestions, comments or letters to: [mhrstaff@usba.org](mailto:mhrstaff@usba.org)

'BYE KEVIN MORAN

by Bruce Carter

It is with a heavy heart that I write this note about a guy I had so many fun times with. I know I will no longer meet up with Kev and reminisce about our times together. Yet there is this sense of relief to know that Kevin is in no more pain, no longer restricted to his unit and frustrated about not being able to join his mates and have a throw at a local park. And the joy he will have in meeting up with his dear mate Brother Brian Thomas who shared many wonderful hours together.

It is Monday morning, and the news of Kevin Moran's death on Thursday, January 6, has just arrived from Sydney. Immediately into action ring a few boomerang chuckers. But find myself drifting into the thoughts which will fill this letter. How ironic – last night David Richardson dropped around a video of the olden days of boomerang throwing, narrated by my old mate BT himself. So boomerangs have been on my mind. What do I do when I get the news that we all knew was not far away from being delivered? I don't feel like a throw, sit down at the keyboard and put on a CD made by another boomeranger mate from interstate, Sam Blight, who I spent more time with overseas chucking rangers around than here in our own. I never did spend much time with Kevin at tournaments. We spoke, sure! But it was our special trips overseas where we made our 'connection'.

A parochial Aussie he was a fine team mate who simply loved his Aussie team and the sport of boomerang throwing. In Geneva, he witnessed Robbie Croll be knocked out cold by a stray fast catch boom that hit him in the back of the head. It was Kevin who went with Rob in the ambulance to the local hospital.

But it was Kev who we saw back at the field within an hour. "How come you are back so quick?" Kev. "Rob is OK on hospital – it is you guys (the Australian team) that really needs my support. Croll will survive but I don't know if this team can without my help!"

But some of my favorite stories with Kev happened in Sydney. He threw as often as possible with his great mate Adam Carroll at the Sydney university fields.. But he seemed to always lock his key in the car. Or worse still, in the boot after he would open the trunk to get out his booms then drop the keys into the boot. So one evening as dusk approached, Adam was sick of Kevin losing his keys and decided to teach him a lesson. He just drove off and left Kevin to fend for himself to get assistance. After that Kevin would always greet me with – "Adam left me like a shag on a rock. Drove off and left me," and his arms would be out stretched, "just dumped me. What a mate!" But he did not hold grudges and the 3 of us had many hours of fun discussing the night Kev was dumped! Kevin, we will all miss you. Say hello to BT, Bunny, Jack and the other boom chuckers. Thanks for your stories and your friendship.

Kevin Moran R.I.P.

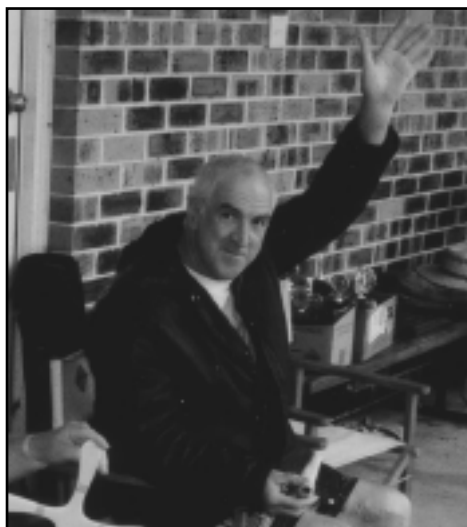

## Next Issue:

- ...Another interview with Dave Hughes, who will it be?
- ...The Sporting News will feature a well known Boomer from California who is often heard from but never seen.
- ...Coverage of the '04 US National Championships and Expo
- ...Information on the US Boomerang Team Camps for 2005
- ...We will run-down Dave Hughes of the Texas Boomerang Society for a detailed look at the recent Long Distance Shootout
- ...Continued breakdown of the Fast-Catch event, highlighting boomerang selection and tuning.
- ...More Plans
- ...More Pictures
- ...More News

## What we need:

- ...Your letters and opinions, next issue will have a section to post the information we receive from you. Want to be heard? Here's your chance.
- ...Your event information for any 2005 boomerang tournament or official get-together.
- ...More Plans
- ...More Pictures
- ...More News

[www.coloradoboomerangs.com](http://www.coloradoboomerangs.com)

**Like To Play  
With Yourself?**

# BOOMERANGS!

- ◆ Crafted from the finest aircraft grade birch plywood
- ◆ Guaranteed to return
- ◆ 30 models to choose from
- ◆ Comes with detailed instructions
- ◆ Prices range from \$14 to \$30
- ◆ Dealer Inquiries Welcome

Call for free catalog:

**800-35-rangs**  
(800-357-2647)

**Hand  
Made in  
Gunnison, CO**



United States Boomerang Association  
3551 236th Street SW  
Brier, WA 98036-8421